

CFS600A Coriolis Flow Sensor



- ▶ The high performance meter for process industries
- ▶ Cryogenic, high temperature and high pressure options
- ▶ Supreme liquid and gas performance with CT approval

Equipment should be installed, operated, serviced, and maintained only by qualified personnel.

No responsibility is assumed by Schneider Electric for any consequences arising from the use of this material.

1	Product features	3
<hr/>		
1.1	The solution for extended temperature applications	3
1.2	Features and options	6
1.3	Meter / transmitter combinations	7
1.4	Measuring principle (twin tube)	7
2	Technical data	10
<hr/>		
2.1	Technical data	10
2.2	ATEX temperature limits	16
2.2.1	Standard temperature meters	16
2.2.2	Short stem meters	18
2.2.3	High temperature meters	20
2.3	Guidelines for maximum operating pressure	22
2.4	Dimensions and weights	29
2.4.1	Flanged versions	29
2.4.2	NAMUR dimensions	39
2.4.3	Hygienic versions	40
2.4.4	Heating jacket version	44
2.4.5	Purge port option	46
2.4.6	Burst disc option	47
3	Installation	48
<hr/>		
3.1	Intended use	48
3.2	Mounting restrictions	48
3.2.1	General installation principles	48
3.2.2	Maximum pipework forces (end loadings)	50
3.2.3	Sunshades	50
4	Model codes	51
<hr/>		

1.1 The solution for extended temperature applications

A high level of performance, together with a wide operating temperature range up to 400°C / 752°F, makes the CFS600A the ideal choice for mass flow measurement in a wide variety of applications.

Designed to meet the requirements of general purpose liquid and gas applications, the extended low temperature range of -200°C / -328°F also makes the CFS600A suitable for Liquid Natural Gas (LNG) and cryogenic applications.

Combined with the power of the CFT34A, the CFS600A will provide accurate measurement of volume, mass, density and concentration.

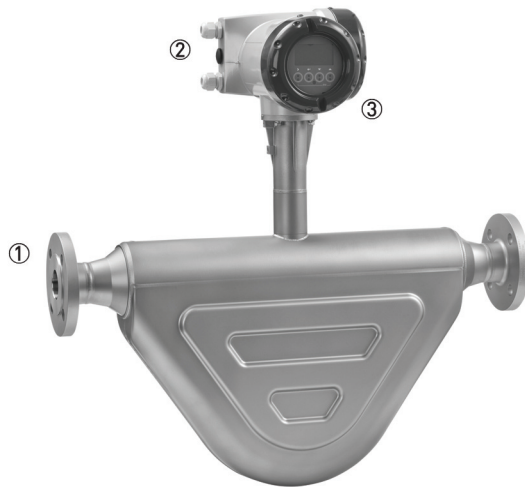

- ① Standard flange process connections available.
- ② Modular electronics with a range of output options.
- ③ Comprehensive diagnostic capabilities.



① Remote terminal box

Features:

- Innovative twin V-tube design
- Temperature range -200°C to +400°C
- Optional insulation / heating jacket
- Compact envelope
- Optimised flow divider for minimum pressure loss
- Modular electronics concept: electronics and sensor are easy to replace
- Self draining when mounted vertically
- Stability with entrained gas, even with gas concentrations 0...100%

Industries:

- Water and waste water
- Chemical
- Oil and gas
- Food and beverage
- Pharmaceutical

Applications:

- Crystallising, solidifying and cryogenic products
- Tanker loading
- General purpose applications
- CIP and SIP >130°C
- Liquid Natural Gas (LNG)
- Supercritical gases

1.2 Features and options

Features



- Available as compact or remote.
- Nominal flow rates up to 550000 kg/h / 20209 lb/min.
- Self draining, when mounted vertically.
- With advanced Entrained Gas Control the meter maintains operation over a wide range of gas fractions and complex flow conditions.

Connection options



- Standard flanges with ratings up to 1500 lb / PN160.
- Supports a wide range of industry standard hygienic connections.
- Optional sealing faces.
- NAMUR NE132 flange lengths

Heating jacket and purge port

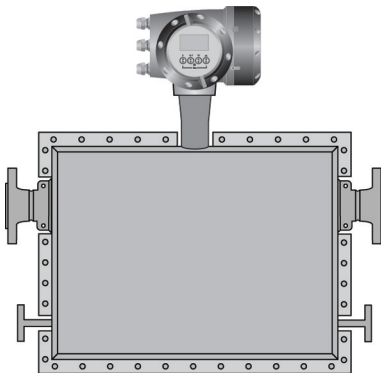

Heating jacket

- For use with temperature dependant products.
- Prevents solidification of process product.
- The heating case can also be used as a cryogenic insulation case.

Purge port

- Allows hazardous chemicals to be drained away safely.

1.3 Meter / transmitter combinations

Transmitter	CFT34A	
Configuration	Compact	Remote field
CFS600A	CFS600A(C)	CFS600A(F)

1.4 Measuring principle (twin tube)

Meter from the side, showing tube layout

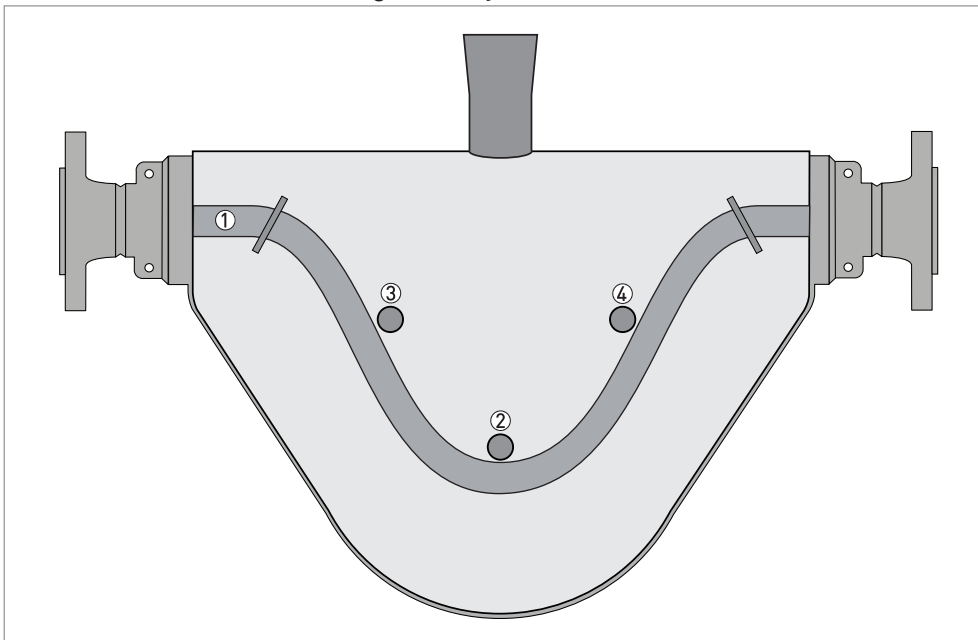

- ① Measuring tubes
- ② Drive coil
- ③ Sensor 1
- ④ Sensor 2

Static meter not energised and with no flow

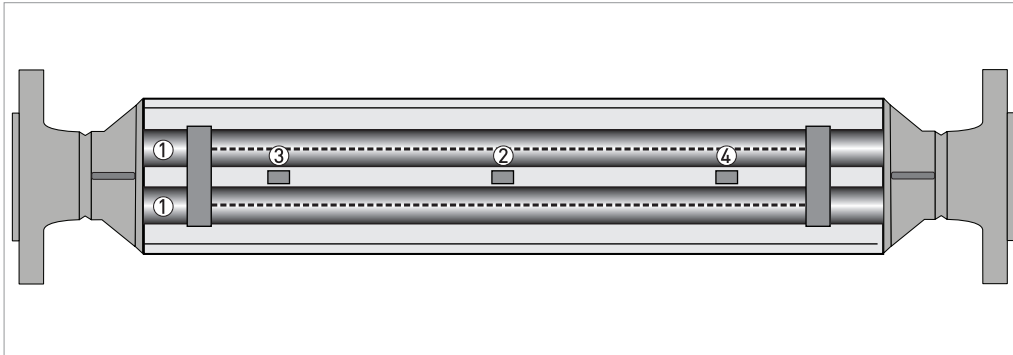

- ① Measuring tubes
- ② Drive coil
- ③ Sensor 1
- ④ Sensor 2

A Coriolis twin tube mass flowmeter consists of two measuring tubes ① a drive coil ② and two sensors (③ and ④) that are positioned either side of the drive coil.

Energised meter

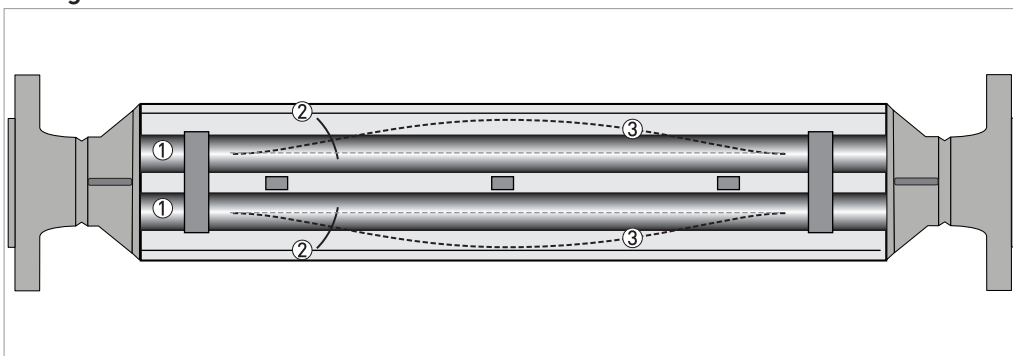

- ① Measuring tubes
- ② Direction of oscillation
- ③ Sine wave

When the meter is energised, the drive coil vibrates the measuring tubes causing them to oscillate and produce a sine wave ③. The sine wave is monitored by the two sensors.

Energised meter with process flow

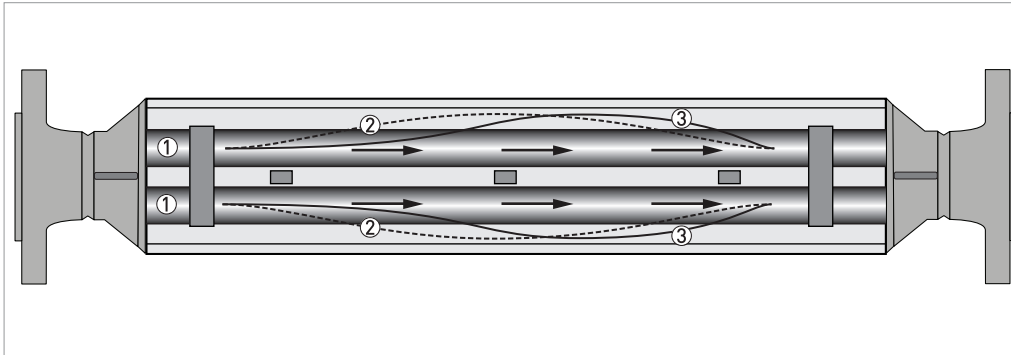

- ① Process flow
- ② Sine wave
- ③ Phase shift

When a fluid or gas passes through the tubes, the coriolis effect causes a phase shift in the sine wave that is detected by the two sensors. This phase shift is directly proportional to the mass flow.

Density measurement is made by evaluation of the frequency of vibration and temperature measurement is made using a Pt500 sensor.

2.1 Technical data

- *The following data is provided for general applications. If you require data that is more relevant to your specific application, please contact us or your local sales office.*
- *Additional information (certificates, special tools, software,...) and complete product documentation can be downloaded free of charge from the website.*

Measuring system

Measuring principle	Coriolis mass flow
Application range	Mass flow and density measurement of fluids, gases and solids
Measured values	Mass, density, temperature
Calculated values	Volume, referred density, concentration, velocity
Sensor model range	
Stainless Steel 316L 08...200	Compact / remote 100 barg @ 20°C / 1450 psig @ 68°F, temp. range -70°C...+230°C / -94°F...+446°F
	Remote only 100 barg @ 20°C / 1450 psig @ 68°F, temp. range -50°C...+400°C / -58°F...+752°F
	Compact / remote 100 barg @ 20°C / 1450 psig @ 68°F, temp. range -200°C...+40°C / -328°F...+104°F
Hastelloy® 08...80	Compact / remote 200 barg @ 20°C / 2900 psig @ 68°F, temp. range -70°C...+400°C / -94°F...+752°F
	Compact / remote 200 barg @ 20°C / 2900 psig @ 68°F, temp. range -50°C...+400°C / -58°F...+752°F
	Remote only 200 barg @ 20°C / 2900 psig @ 68°F, temp. range -196°C...+40°C / -321°F...+104°F
Duplex Stainless Steel 100...200	Compact / remote 200 barg @ 20°C / 2900 psig @ 68°F, temp. range -50°C...+230°C / -58°F...+446°F

Design

Basic	System consists of a measuring sensor and a transmitter to process the output signal
Features	Fully welded maintenance free sensor with twin V-shaped measuring tube
Variants	
Compact version	Integral transmitter
Remote version	Available with a field version of the transmitter

Performance specification

Reference conditions	
Calibration fluid	Water
Calibration temperature	+20°C / +68°F (± 5°C)
Calibration pressure	1...6 barg / 14.5...87 psig
Calibration rig	Accreditation satisfies the requirements of BS EN ISO / IEC 17025
Mass flow (standard)	
Liquid flow rate ≥ zero stability × 1000	

Base accuracy	±0.1% of actual measured flow rate	
Repeatability	Better than 0.05% of measured flow rate	
Liquid flow rate < zero stability × 1000		
Base accuracy	±zero stability (see zero stability below)	
Repeatability	Better than zero stability × 0.5	
Gas	Better than 0.35% plus zero stability	
Repeatability	Better than 0.2% plus zero stability	
Mass flow (optional)		
Liquid flow rate ≥ zero stability × 2000		
Base accuracy	0.05% of measured flow rate	
Repeatability	Better than 0.025% of measured flow rate	
Liquid flow rate < zero stability × 2000		
Base accuracy	±zero stability	
Repeatability	Better than zero stability × 0.5	
Zero stability		
Meter size	Standard temperature	High temperature
08	< 0.03 kg/h	< 0.48 kg/h
10	< 0.06 kg/h	< 0.096 kg/h
15	< 0.19 kg/h	< 0.304 kg/h
25	< 0.95 kg/h	< 1.52 kg/h
50	< 1.75 kg/h	< 2.80 kg/h
80	< 3.90 kg/h	< 6.24 kg/h
100	< 8.75 kg/h	< 14.00 kg/h
150	< 16.00 kg/h	< 25.60 kg/h
200	< 27.50 kg/h	< 44.00 kg/h
Effect on sensor zero point caused by a deviation in process temperature from zero calibration temperature		
Standard temperature range		
All materials sizes 08...10	0.0010% of nominal flow per 1°C / 0.00056% of nominal flow per 1°F	
All materials sizes 15...200	0.00075% of nominal flow per 1°C / 0.00042% of nominal flow per 1°F	
High temperature range		
All materials sizes 08...200	0.008% of nominal flow per 1°C / 0.0044% of nominal flow per 1°F	
Pressure effect on mass flow rate		
All materials sizes 08...50	-0.005% of reading per 1 barg / -0.00034 % per 1 psig	
All materials sizes 80...100	-0.0055% of reading per 1 barg / -0.00038 % per 1 psig	
All materials sizes 150...200	-0.008% of reading per 1 barg / -0.00055 % per 1 psig	
Density		
Measuring range	100...3000 kg/m ³ / 6...187 lb/ft ³	
Base accuracy	±1 kg/m ³ / ±0.06 lb/ft ³	
Repeatability / on site calibration	±0.3 kg/m ³ / ±0.015 lb/ft ³	

Process temperature effect of deviation from calibration temperature	
All materials / meter sizes	Better than 0.015 g/l per 1°C / 0.0083 g/l per 1°F
Pressure effect on density of deviation from calibration pressure (based on reference density = 1000 kg/m³)	
All materials size 08	+0.038 kg/m ³ per bar
All materials sizes 10...15	+0.026 kg/m ³ per bar
All materials sizes 25...80	+0.017 kg/m ³ per bar
All materials sizes 100...150	+0.011 kg/m ³ per bar
Volume flow	
Measurement error and repeatability calculations satisfy the requirements of BS ISO 10790 (most recent and up to date version)	
Temperature	
Measurement error	± 0.5°C ± 0.5% of reading / ±0.9°F ± 0.5% of reading

Operating conditions

Nominal flow rates (1 barg / 14.5 psig pressure drop)	
08	600 kg/h / 22 lb/min
10	1200 kg/h / 44 lb/min
15	3800 kg/h / 139 lb/min
25	19000 kg/h / 698 lb/min
50	35000 kg/h / 1286 lb/min
80	78000 kg/h / 2866 lb/min
100	175000 kg/h / 6430 lb/min
150	320000 kg/h / 11758 lb/min
200	550000 kg/h / 20209 lb/min
	Assumes operating density 1000 kg/m ³ / 62.4 lb/ft ³
	For Hastelloy® meters, assume a pressure drop of 1.15 barg
Maximum flow rates	
All meters	150% of nominal flow rate

Environmental

Ambient temperature		
Compact meter	Standard transmitter	SIL capable transmitter
Aluminium transmitter	-40...+65°C / -40...+149°F	-40...+55°C / -40...+131°F
Stainless Steel transmitter	-40...+60°C / -40...+140°F	-40...+55°C / -40...+131°F
Remote meter	Standard transmitter	SIL capable transmitter
Standard temperature range	-40...+65°C / -40...+149°F	-40...+55°C / -40...+131°F
Cryogenic temperature range	-20...+65°C / -4...+149°F	-40...+55°C / -40...+131°F
Hazardous Area versions	Refer to temperature limits	
Protection category (Acc. to EN 60529)	IP 66 / 67, NEMA 4X	
Vibration (acc IEC 60068-2-6)	10-150-10 Hz with 0.15 mm for 10...60 Hz, 20 m/s ² for 60...150 Hz	

Process temperatures		
Standard temperature range (flange connections)	Extended stem	Short stem
Safe area	-70...+230°C / -94...+446°F	-70...+150°C / -94...+302°F
Hazardous area	-50...+230°C / -58...+446°F	-50°C...+150°C / -58...+302°F
High temperature range	-50...+400°C / -58...+752°F	N/A
Cryogenic temperature range	-200...+40°C / -328...+104°F	-200...+40°C / -328...+104°F
Standard temperature range (hygienic connections)	Extended stem	Short stem
Safe area	-70...+150°C / -94...+302°F	-70...+150°C / -94...+302°F
Hazardous area	-50...+150°C / -58...+302°F	-50...+150°C / -58...+302°F
Nominal pressure at 20°C / 68°F		
Measuring tube	SS 316 / 316L	Hastelloy® C22 / S31803
FM / PED	-1...100 barg / -14.5...1450 psig	-1...200 barg / -14.5...2900 psig
CRN / ASME B31.3	-1...100 barg / -14.5...1450 psig	Pending
Outer casing burst pressure ①		
08	≈ 100 barg	
10		
15		
25		
50	≈ 70 barg	
80		
100	≈ 10 barg	
150		
200		
If the process temperature is higher than 20°C / 68°F, the burst pressure will be lower. For more information please contact the manufacturer.		
Fluid properties		
Permissible physical condition	Liquids, gases, slurries	
Permissible gas content (volume)	Contact manufacturer for information.	
Permissible solid content (volume)	Contact manufacturer for information.	
Installation conditions		
Inlet / outlet runs	None required	

Materials

Stainless Steel (316 / 316L) meter	
Measuring tubes / Flanges	Stainless Steel AISI 316 / 316L (1.4401 / 1.4404) dual certified
Spigots	Stainless Steel CF3M (1.4409)
Bridge	AISI 316 / 316L (1.4401 / 1.4404) dual certified
Outer casing	Stainless Steel AISI 316 / 316L (1.4401 / 1.4404) dual certified
Stainless Steel (S31803) meter	
Measuring tubes / Flanges	Stainless Steel UNS 31803 (1.4462)

Spigots	Stainless Steel J92205 (1.4470)
Bridge	AISI 316 / 316L (1.4401 / 1.4404) dual certified
Outer casing	Stainless Steel AISI 316 / 316L (1.4401 / 1.4404) dual certified
Hastelloy® C22 meter	
Measuring tubes / raised face	Hastelloy® C22
(Backing) flanges	Stainless Steel AISI 316 / 316L (1.4401 / 1.4404) dual certified
Bridge	Stainless Steel AISI 316 / 316L (1.4401 / 1.4404) dual certified
Outer casing	Stainless Steel AISI 316 / 316L (1.4401 / 1.4404) dual certified
Heating jacket version	
Heating loop and insulation jacket	Stainless Steel AISI 316 (1.4401)
All versions	
Junction box (remote version)	Die-cast Aluminium (polyurethane coating)
	Optional Stainless Steel 316 (1.4401)

Process connections

Flange	
DIN	DN10...200 / PN16...160
ASME	½...8" / ASME 150...1500
JIS	10A...100A / 10...20K (10K maximum allowable temperature 300°C / 572°F)
Hygienic	
Tri-clover	½...4"
Tri-clamp DIN 32676	DN15..100
Tri-clamp ISO 2852	1...4"
DIN 11864-2 Form A	DN15...100
Male thread DIN 11851	DN15...100
Male thread SMS	25...100 mm / 1...4"

Electrical connections

Electrical connections	For full details, including: power supply, power consumption etc., see technical data for the relevant transmitter.
I/O	For full details of I/O options, including data streams and protocols, see technical data for the relevant transmitter.

Approvals

CE	The device fulfils the statutory requirements of the CE directive. The manufacturer certifies that these requirements have been met by applying the CE mark.
----	--

cFMus	Compact and transmitter
	Class I, Div 1, Groups A,B,C and D (US)
	Class I, Div 1, Groups C and D.(Canada)
	Class II, Div 1, Groups E, F and G
	Class III Div 1 T6...T1
	Class I, Div 2 Groups A,B,C and D
	Class II Div 2 Groups F and G
	Class III Div 2 T6...T1
	Remote (sensor only)
	Class I Div 1 Groups A,B,C and D
	Class I Div 2 Groups A,B,C and D
	Class II Div 1 Groups E,F and G
	Class III Div 1 T6...T1
	Class II Div 2 Groups F and G
	Class III Div 2 T6...T1
CRN	acc to: ASME B31.3 (most recent and up to date version)
NACE	MR0175 / ISO 15156 ("Sulphide Stress Corrosion Cracking Resistant Metallic Materials for Oil Field Equipment") and MR0103 ("Materials Resistant to Sulfide Stress Cracking in Corrosive Petroleum Refining Environments") (most recent and up to date versions)
Custody transfer	Measuring Instruments Directive (MID) MI 002 and MI 005 (most recent and up to date version)
	OIML R117-1
	OIML R137
	Compliant with API and AGA
Functional safety	SIL2 / SIL3 (acc to: IEC 61508)
ATEX (most recent and up to date version)	
Ex d connection compartment	II 1/2 G Ex db ia IIC T6...T1 Ga/Gb
	II 2 D Ex tb IIIC T270°C Db
Ex e connection compartment	II 1/2 G Ex db eb ia IIC T6...T1 Ga/Gb
	II 2 D Ex tb IIIC T270°C Db
Ex d connection compartment	II 1/2(1) G Ex db ia [ia Ga] IIC T6...T1 Ga/Gb
	II 2(1) D Ex tb [ia Da] IIIC T270°C Db
Ex e connection compartment	II 1/2(1) G Ex db eb ia [ia Ga] IIC T6...T1 Ga/Gb
	II 2(1) D Ex tb [ia Da] IIIC T270°C Db
	II 1 G Ex ia IIC T6...T1 Ga
	II 1 D Ex ia IIIC T270°C Da
	II 1 D Ex ia IIIC T440°C Da

① For information only. Secondary pressure containment is NOT supplied on this meter

2.2 ATEX temperature limits

2.2.1 Standard temperature meters

	Ambient temp. T_{amb} °C	Max medium temp. T_m °C	Temp. class	Max. Surface temp. °C	
CFS600A(F) with or without heating jacket / insulation	-40...+40	40	T6 - T1	T80	
		55	T5 - T1	T95	
		90	T4 - T1	T130	
		150	T3 - T1	T190	
		230	T2 - T1	T270	
	-40...+50	40	T6 - T1	T80	
		55	T5 - T1	T95	
		90	T4 - T1	T130	
		150	T3 - T1	T190	
		230	T2 - T1	T270	
	-40...+65	40	T6 - T1	T80	
		55	T5 - T1	T95	
		90	T4 - T1	T130	
		150	T3 - T1	T190	
		230	T2 - T1	T270	
	Minimum medium temp: -50°C				
	Cryogenic version ("q" = C or D and "k" = 0, 2 or A)				
	-25...+65	-140...+40	T6 - T1	T80	
		-160...+40			
-20...+65	-180...+40				
	-200...+40				
Minimum medium temp: <-50°C					

CFS600A(C) – aluminium transmitter housing with or without heating jacket / insulation	-40...+40	40	T6 - T1	T80	
		55	T5 - T1	T95	
		90	T4 - T1	T130	
		150	T3 - T1	T190	
		230	T2 - T1	T270	
	-40...+50	40	T6 - T1	T80	
		55	T5 - T1	T95	
		90	T4 - T1	T130	
		150	T3 - T1	T190	
		230	T2 - T1	T270	
	-40...+65	65	T4 - T1	T105	
	Minimum medium temp: -50°C				
	Cryogenic version ("q" = C or D and "k" = 0, 2 or A)				
	-35...+65	-140...+40	T6 - T1	T80	
					-160...+40
		-30...+65			-180...+40
	-25...+65	-200...+40			
	Minimum medium temp: < -50°C				
	CFS600A(C) – SS transmitter housing with or without heating jacket / insulation	-40...+40	40	T6 - T1	T80
			55	T5 - T1	T95
90			T4 - T1	T130	
150			T3 - T1	T190	
230			T2 - T1	T270	
-40...+50		40	T6 - T1	T80	
		55	T5 - T1	T95	
		90	T4 - T1	T130	
		150	T3 - T1	T190	
		230	T2 - T1	T270	
-40...+60		60	T4 - T1	T100	
Minimum medium temp: -50°C					
Cryogenic version ("q" = C or D and "k" = 0, 2 or A)					
-35...+60		-140...+40	T6 - T1	T80	
					-160...+40
-30...+60		-180...+40			
-25...+60		-200...+40			
Minimum medium temp: < -50°C					

2.2.2 Short stem meters

	Ambient temp. T_{amb} °C	Max medium temp. T_m °C	Temp. class	Max. Surface temp. °C	
CFS600A(F) short stem without heating jacket / insulation	-40...+40	40	T6 - T1	T80	
		55	T5 - T1	T95	
		90	T4 - T1	T130	
		150	T3 - T1	T190	
	-40...+50	40	T6 - T1	T80	
		55	T5 - T1	T95	
		90	T4 - T1	T130	
		150	T3 - T1	T190	
	-40...+65	40	T6 - T1	T80	
		55	T5 - T1	T95	
		90	T4 - T1	T130	
		135	T3 - T1	T175	
	Minimum medium temp: -50°C				
	Cryogenic version ("q" = C or D and "k" = 0 or A)				
	+10...+65	-140...+40	T6 - T1	T80	
	+20...+65	-160...+40			
+30...+65	-180...+40				
+40...+65	-200...+40				
Minimum medium temp: <-50°C					
CFS600A(C) short stem with aluminium transmitter housing without heating jacket / insulation	-40...+40	40	T6 - T1	T80	
		55	T5 - T1	T95	
		90	T4 - T1	T130	
		150	T3 - T1	T190	
	-40...+50	40	T6 - T1	T80	
		55	T5 - T1	T95	
		90	T4 - T1	T130	
		145	T3 - T1	T185	
	-40...+65	65	T4 - T1	T105	
	Minimum medium temp: -50°C				
	Cryogenic version ("q" = C or D and "k" = 0 or A)				
	-20...+65	-140...+40	T6 - T1	T80	
	-15...+65	-160...+40			
		-180...+40			
	-10...+65	-200...+40			
	Minimum medium temp: <-50°C				

CFS600A(C) short stem with SS transmitter housing without heating jacket / insulation	-40...+40		40	T6 - T1	T80
			55	T5 - T1	T95
			90	T4 - T1	T130
			150	T3 - T1	T190
	-40...+50		40	T6 - T1	T80
			55	T5 - T1	T95
			90	T4 - T1	T130
			145	T3 - T1	T185
	-40...+60		60	T4 - T1	T100
	Minimum medium temp: -50°C				
	Cryogenic version ("q" = C or D and "k" = 0 or A)				
	-10...+60	-140...+40	T6 - T1		T80
	-5...+60	-160...+40			
	0...+60	-180...+40			
	+10...+60	-200...+40			
Minimum medium temp: <-50°C					

2.2.3 High temperature meters

	Ambient temp. T_{amb} °C	Max medium temp. T_m °C	Temp. class	Max. Surface temp. °C	
CFS600A(F) high temperature with aluminium junction box and heating jacket	-40...+40	40	T6 - T1	T80	
		55	T5 - T1	T95	
		90	T4 - T1	T130	
		150	T3 - T1	T190	
		230	T2 - T1	T270	
		400	T1	T440	
	-40...+55	40	T6 - T1	T80	
		55	T5 - T1	T95	
		90	T4 - T1	T130	
		150	T3 - T1	T190	
		230	T2 - T1	T270	
		400	T1	T440	
	-40...+60	40	T6 - T1	T80	
		55	T5 - T1	T95	
		90	T4 - T1	T130	
		150	T3 - T1	T190	
		230	T2 - T1	T270	
		400	T1	T440	
	-40...+65	350		T390	
	Minimum medium temp: -50°C				

CFS600A(F) high temperature with stainless steel junction box and heating jacket.	-40...+40	40	T6 - T1	T80	
		55	T5 - T1	T95	
		90	T4 - T1	T130	
		150	T3 - T1	T190	
		230	T2 - T1	T270	
		400	T1	T440	
	-40...+50	40	T6 - T1	T80	
		55	T5 - T1	T95	
		90	T4 - T1	T130	
		150	T3 - T1	T190	
		230	T2 - T1	T270	
		400	T1	T440	
	-40...+55	40	T6 - T1	T80	
		55	T5 - T1	T95	
		90	T4 - T1	T130	
		150	T3 - T1	T190	
		230	T2 - T1	T270	
		400	T1	T440	
	-40...+60	350		T390	
	Minimum medium temp: -50°C				
	CFS600A(F) high temperature with aluminium or stainless steel junction box and no heating jacket	-40...+40	40	T6 - T1	T80
55			T5 - T1	T95	
90			T4 - T1	T130	
150			T3 - T1	T190	
230			T2 - T1	T270	
400			T1	T440	
-40...+55		40	T6 - T1	T80	
		55	T5 - T1	T95	
		90	T4 - T1	T130	
		150	T3 - T1	T190	
		230	T2 - T1	T270	
		400	T1	T440	
-40...+65		40	T6 - T1	T80	
		55	T5 - T1	T95	
		90	T4 - T1	T130	
		150	T3 - T1	T190	
		230	T2 - T1	T270	
		400	T1	T440	
Minimum medium temp: -50°C					

2.3 Guidelines for maximum operating pressure

Always make sure that the meter is used within its operating limits.

**Pressure / temperature de-rating (metric) for meters with SS 316 measuring tubes.
Standard temperature range.**

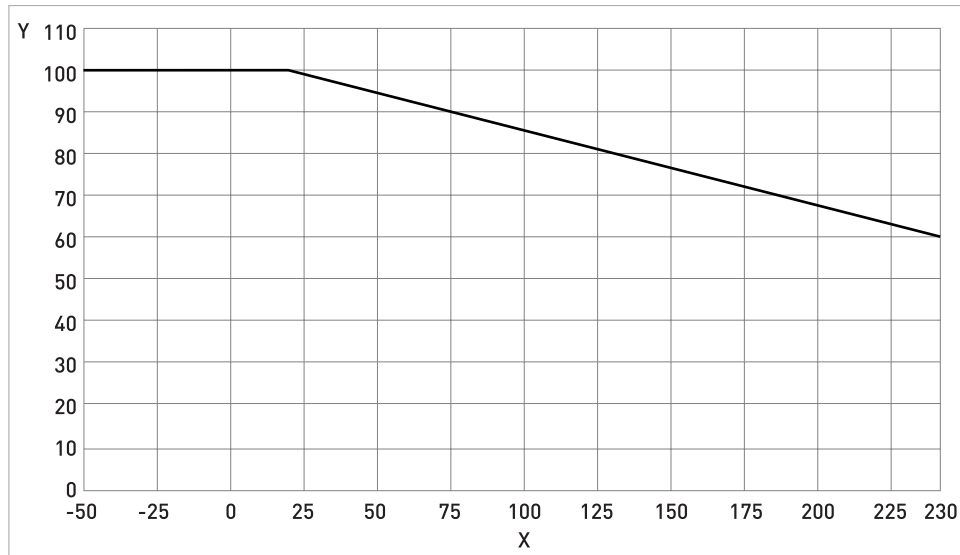

Figure 2-1: Measuring tube PED certification

X temperature [°C]
Y pressure [barg]

**Pressure / temperature de-rating (imperial) for meters with SS 316 measuring tubes.
Standard temperature range.**

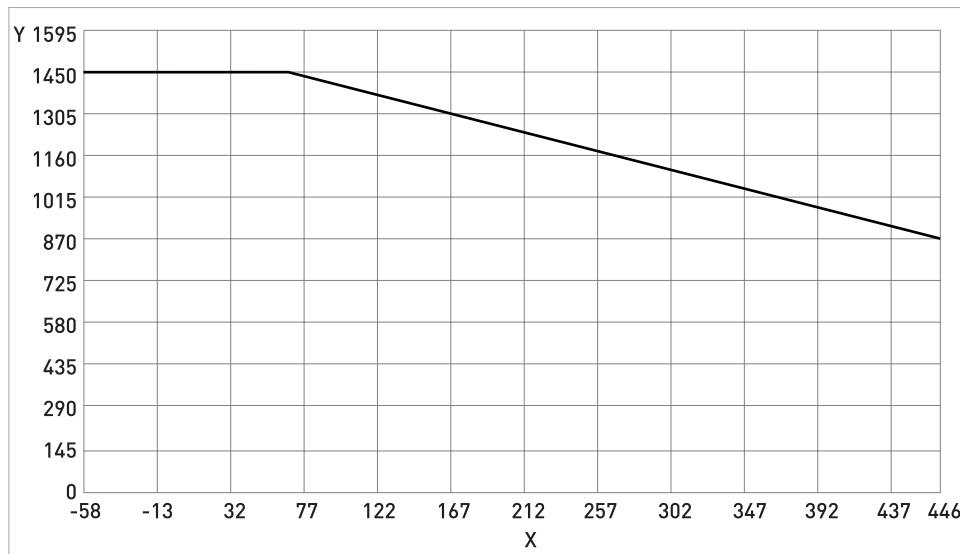
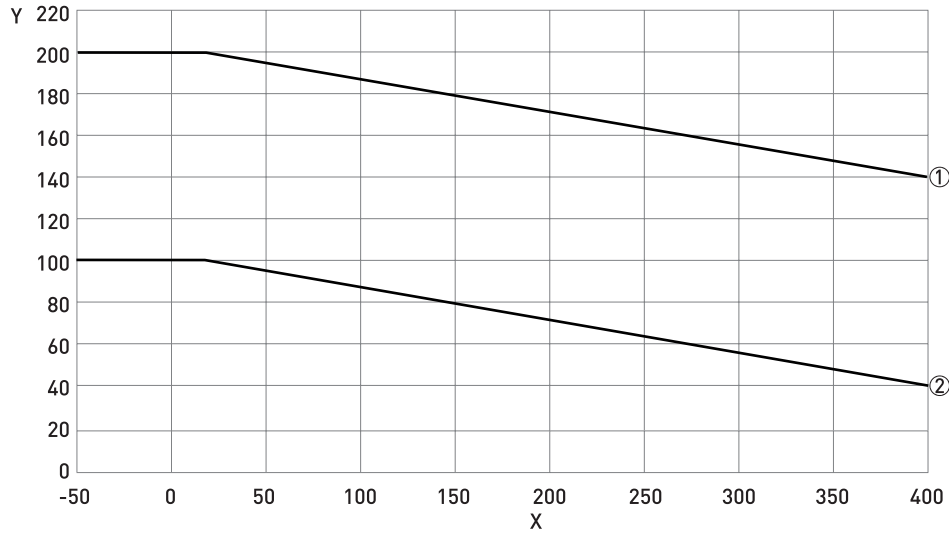

Figure 2-2: Measuring Tube PED certification

X temperature [°F]
Y pressure [psig]

Pressure / temperature de-rating (metric) for meters with SS 316 and Hastelloy®C22, PED certified measuring tubes. High temperature range.



X temperature [°C]

Y pressure [barg]

① Hastelloy® C22 08...80

② Stainless Steel 316 08...200

Pressure / temperature de-rating (imperial) for meters with SS 316 and Hastelloy® C22, PED certified measuring tubes. High temperature range.

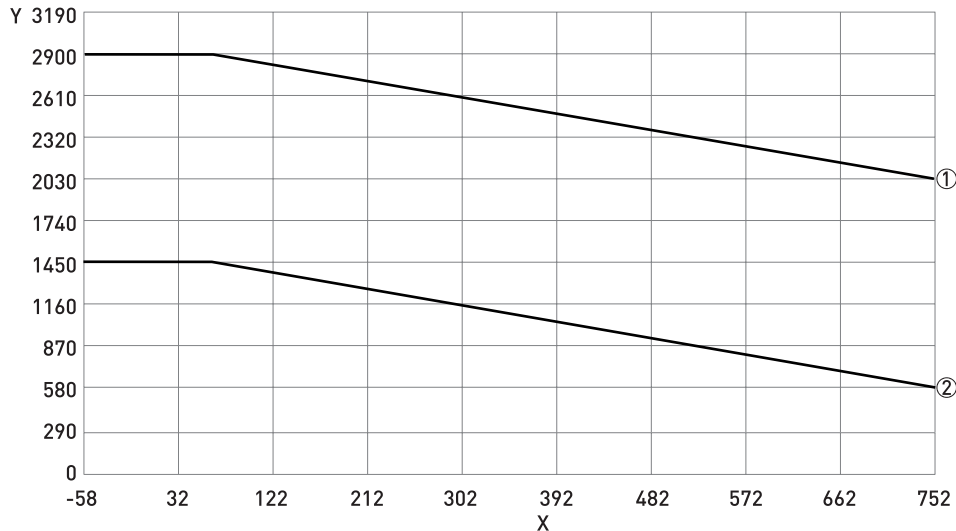

X temperature [°F]

Y pressure [psig]

① Hastelloy® C22 08...80

② Stainless Steel 316 08...200

Pressure / temperature de-rating (metric) for meters with SS 31803 and Hastelloy® C22, PED certified measuring tubes. Standard temperature range

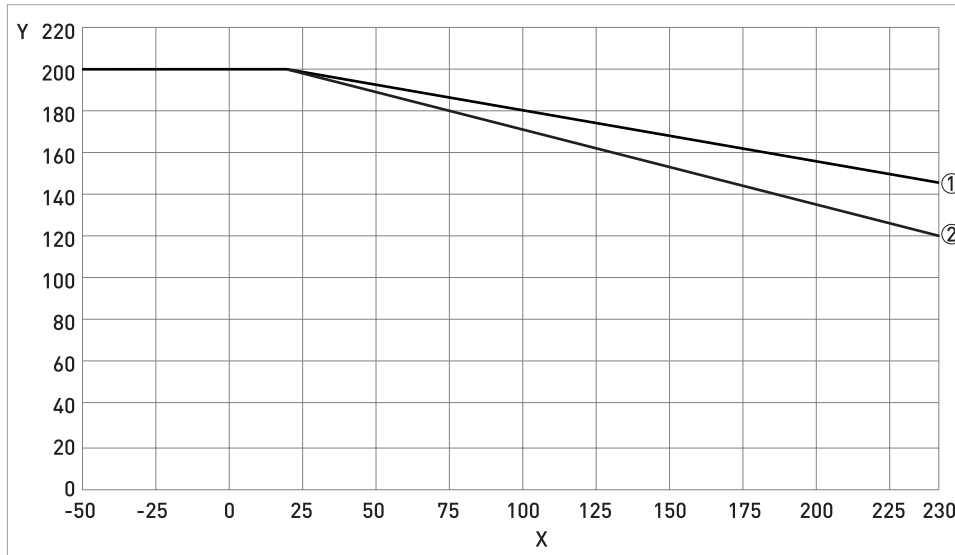

X temperature [°C]
Y pressure [barg]

- ① PED / CRN H08...80, D100
- ② CRN D150...200

Pressure / temperature de-rating (imperial) for meters with SS 31803 and Hastelloy® C22, PED certified measuring tubes. Standard temperature range.

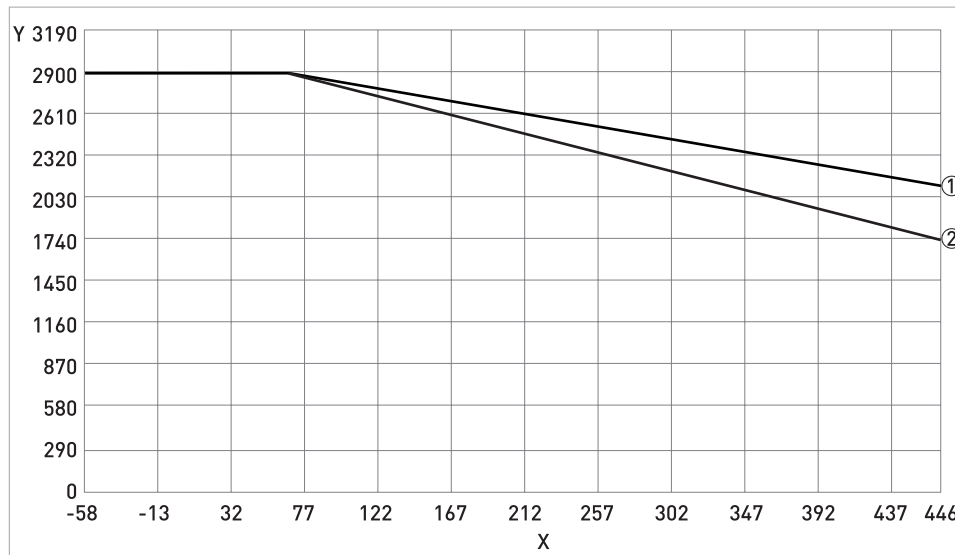

X temperature [°F]
Y pressure [psig]

- ① PED / CRN H08...80, D100
- ② CRN D150...200

Pressure / temperature de-rating (metric) for meters with SS 316, PED certified measuring tubes. Cryogenic temperature range.

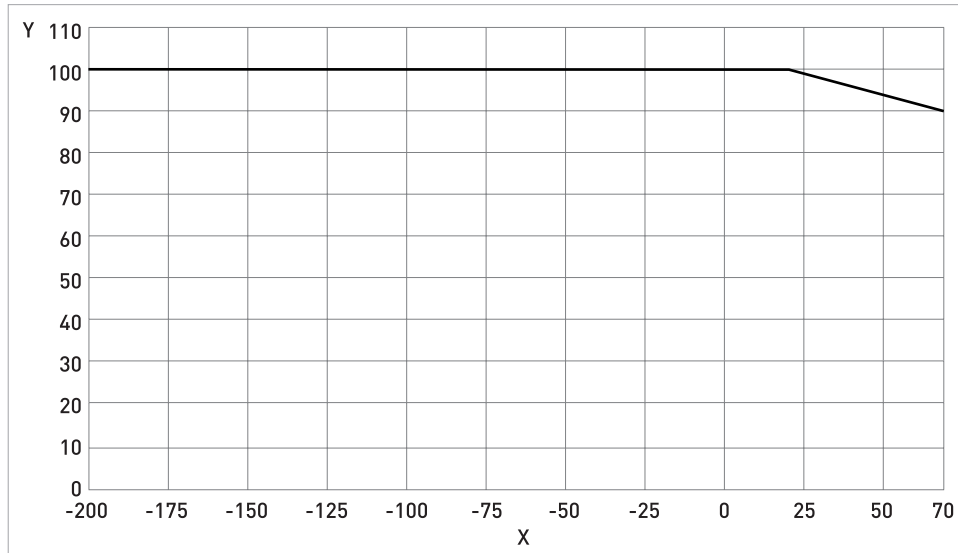

X temperature [°C]
Y pressure [barg]

Pressure / temperature de-rating (imperial) for meters with SS 316 measuring tubes PED certified. Cryogenic temperature range.

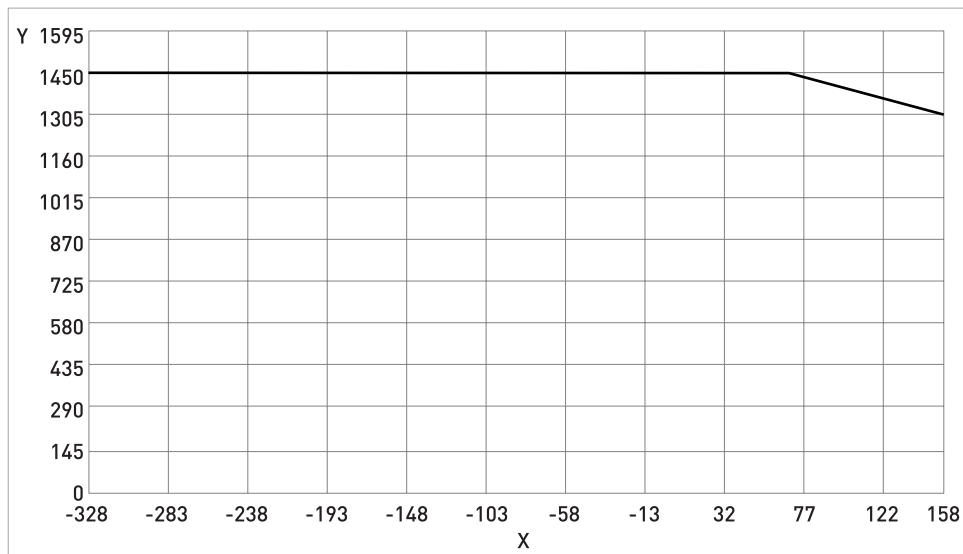

X temperature [°F]
Y pressure [psig]

Pressure / temperature de-rating (metric) for meters with Hastelloy®C22, PED certified measuring tubes. Cryogenic temperature range.

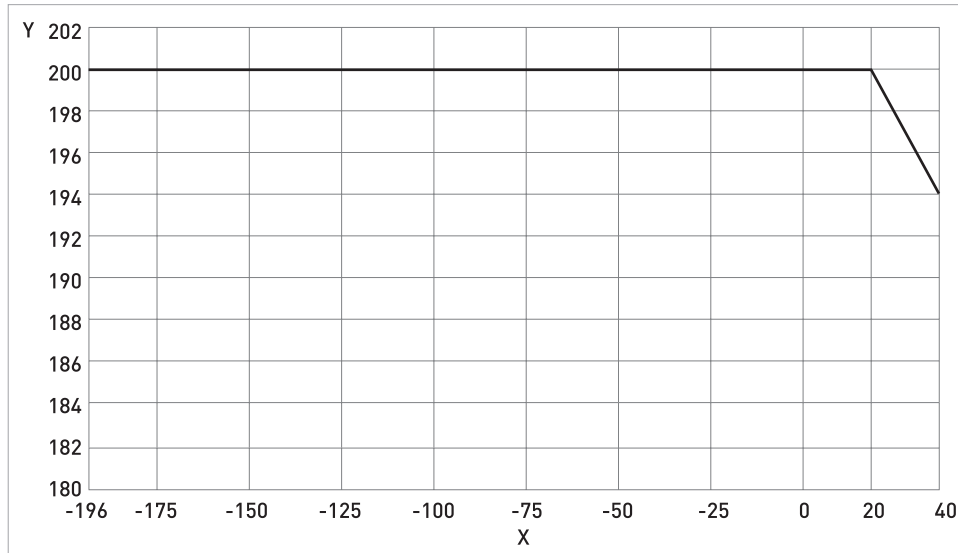

X temperature [°C]
Y pressure [barg]

Pressure / temperature de-rating (imperial) for meters with Hastelloy® C22, PED certified measuring tubes. Cryogenic temperature range.

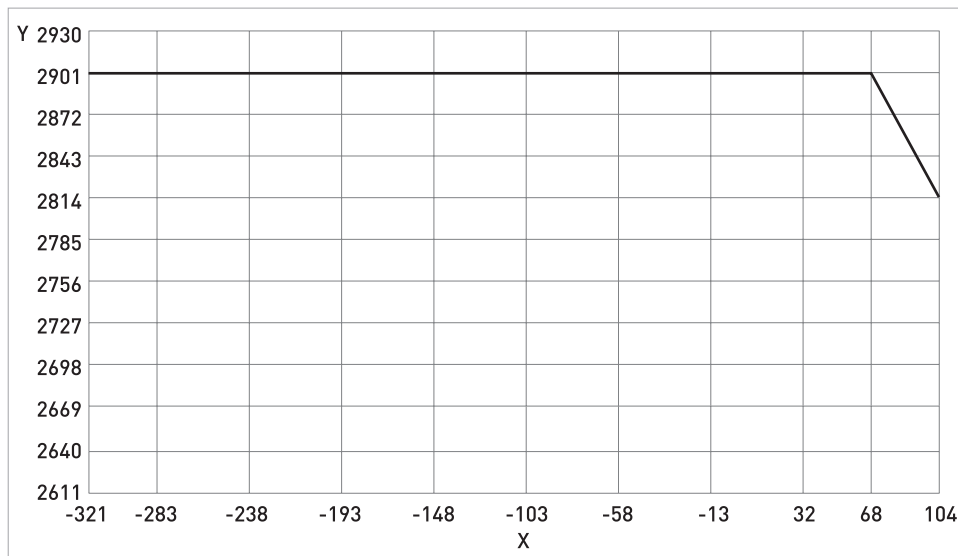

X temperature [°F]
Y pressure [psig]

Flanges

- DIN flange ratings are based on EN 1092-1 2007 table G.4.1 material group 14EO
- ASME flange ratings are based on ASME B16.5 2003 table 2 material group 2.2

- JIS flange ratings are based on JIS 2220: 2001 table 1 division 1 material group 022a
- JIS 10K flanges are limited to a maximum temperature of 300°C / 572°F

Pressure / temperature de-rating (metric) for meters with hygienic connections.

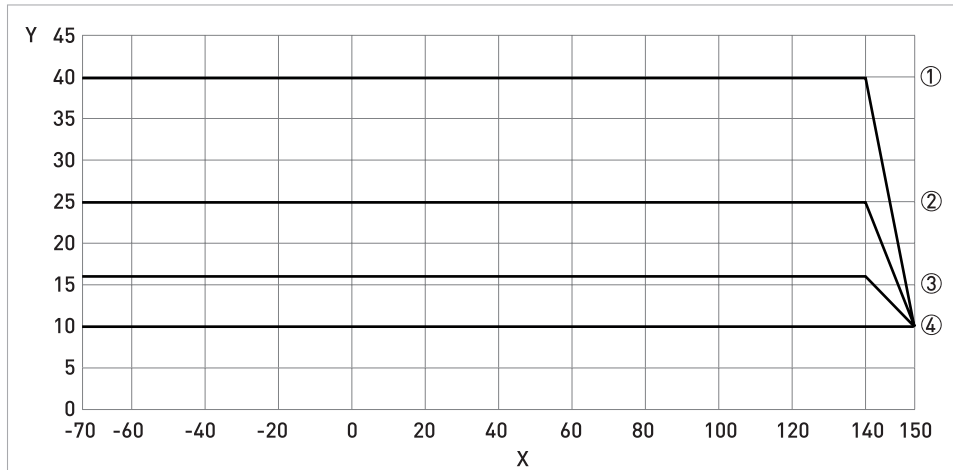

X temperature [°C]

Y pressure [barg]

- ① SMS 1...1½", DIN 11851 DN10...40
- ② SMS 2", Tri-clamp DN10...40, DIN 11864-2 DN10...40, DIN 11851 DN50...65
- ③ SMS 3", Tri-clamp DN50...65, DIN11864-2, DIN11864-2 DN50...100, DN11851 DN80...100
- ④ SMS 4", Tri-clamp DN80...100

Pressure / temperature de-rating (imperial) for meters with hygienic connections.

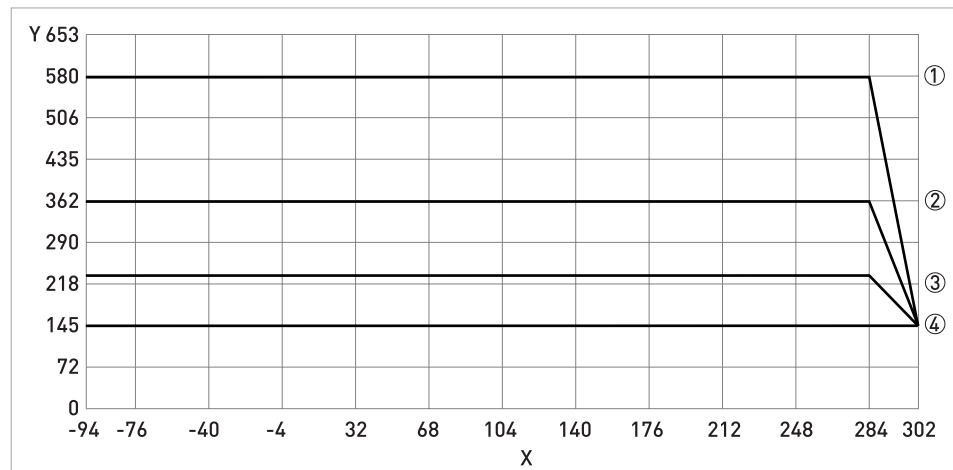

X temperature [°F]

Y pressure [psig]

- ① SMS 1...1½", DIN 11851 DN10...40
- ② SMS 2", Tri-clamp DN10...40, DIN 11864-2 DN10...40, DIN 11851 DN50...65
- ③ SMS 3", Tri-clamp DN50...65, DIN11864-2, DIN11864-2 DN50...100, DN11851 DN80...100
- ④ SMS 4", Tri-clamp DN80...100

Notes

- The maximum operating pressure will be either the flange / hygienic connection rating or the measuring tube rating, **WHICHEVER IS THE LOWER!**
- For hygienic applications above 10 bar, connection sizes DN25...100 / 1...4" are limited to the measurement of liquid at the pressures shown in the above table.
- The maximum pressure for steam cleaning is 10 bar / 145 psi.
- For other applications above 10 bar / 145 psi, please contact the manufacturer.
- The manufacturer recommends that the seals are replaced at regular intervals. This will maintain the hygienic integrity of the connection.

2.4 Dimensions and weights

2.4.1 Flanged versions

Meter weights

	kg								
	S08	S10	S15	S25	S50	S80	S100	S150	S200
Aluminium (compact)	9.3	10.1	12.9	23.5	29.4	58.9	94.3	193.6	443.6
Stainless Steel (compact)	15.2	16.0	18.8	29.4	35.3	64.8	100.2	199.5	449.5
Aluminium (remote)	5.8	6.6	9.4	19.9	25.9	55.4	90.8	190.1	440.0
Stainless Steel (remote)	6.6	7.3	10.2	20.7	26.6	56.1	91.5	191.5	440.8
Heating jacket add	3.1		4.5	7.0	7.9	12.7	15.7	27.6	N/A

	lbs								
	S08	S10	S15	S25	S50	S80	S100	S150	S200
Aluminium (compact)	20.5	22.3	28.4	51.8	64.8	129.8	207.9	426.8	978.0
Stainless Steel (compact)	33.5	35.3	41.4	64.8	77.8	142.9	220.9	439.8	991.0
Aluminium (remote)	12.8	14.5	20.7	43.9	57.1	122.1	200.2	419.1	970.0
Stainless Steel (remote)	14.6	16.1	22.5	45.6	58.6	123.7	201.7	422.2	971.8
Heating jacket add	6.8		9.9	15.4	17.4	28.0	34.6	60.8	N/A

The weights shown are for meters fitted with PN40 flanges. Smaller or larger flange sizes will affect the overall weight. For further information, please contact the manufacturer.

Meter dimensions

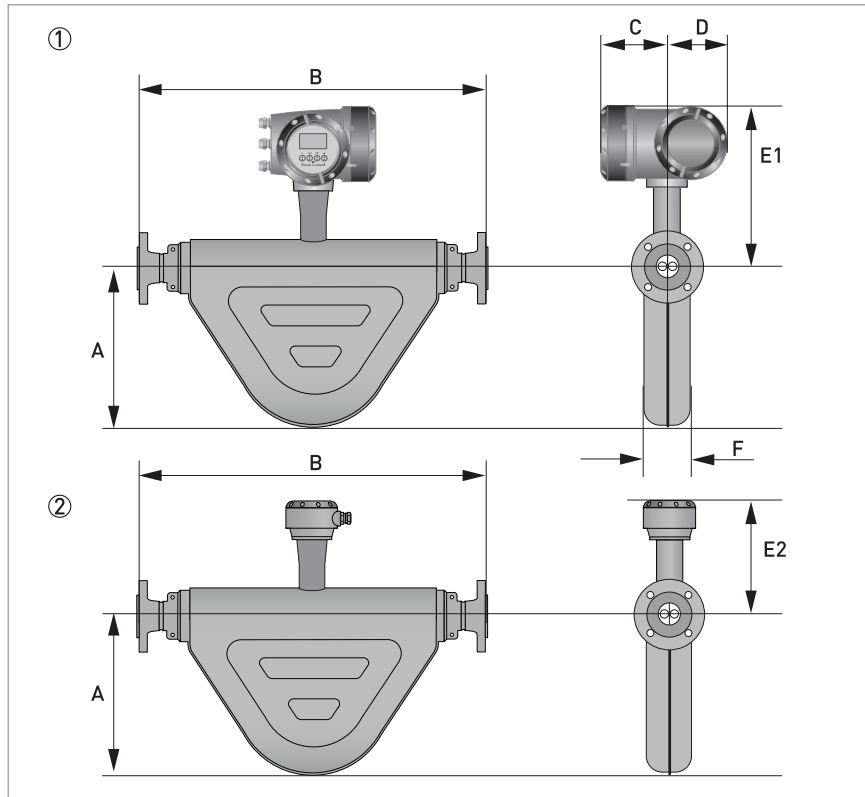

- ① Compact version
② Remote version

General dimensions

	mm								
	S08	S10	S15	S25	S50	S80	S100	S150	S200
A ±3	156	186	282	321	411	453	555	710	
C	137								
D	122								
E1 ±3 ①	279	280	297	333	359	384	426		
E1 ±3 ②	365	366	383	419	445	470	512		
E2 ±3 ③	222		240	246	302	327	369		
E2 ±3 ④	308		326	361	388	413	455		
E2 ±3 ⑤	348		366	401	428	453	495		
F ±2	81		118	131	196	251	273	356	

- ① compact 150°C (short stem)
② compact 230°C (extended stem)
③ remote 150°C (short stem)
④ remote 230°C (extended stem)
⑤ remote 400°C (extended stem)

	inches								
	S08	S10	S15	S25	S50	S80	S100	S150	S200
A ±0.11	6.1		7.3	11.1	12.6	16.2	17.8	21.9	28.0
C	5.4								
D	4.8								
E1 ±0.12 ①	11.0		11.0	11.7		13.1	14.1	15.1	16.8
E1 ±0.12 ②	14.4		14.4	15.1		16.5	17.5	18.5	20.2
E2 ±0.12 ③	8.7		8.7	9.4		9.7	11.9	12.9	14.5
E2 ±0.12 ④	12.1		12.1	12.8		14.2	15.3	16.3	17.9
E2 ±0.12 ⑤	13.7		13.7	14.4		15.8	16.9	17.8	19.5
F ±0.08	3.2			4.6	5.2	7.7	9.9	10.7	14.0

- ① compact 302°F (short stem)
- ② compact 446°F (extended stem)
- ③ remote 302°F (short stem)
- ④ remote 446°F (extended stem)
- ⑤ remote 752°F (extended stem)

Dimension B for meters with Stainless Steel measuring tubes

mm (±5)									
	S08	S10	S15	S25	S50	S80	S100	S150	S200
PN16									
DN80	-	-	-	-	-	-	970	-	-
DN100	-	-	-	-	-	-	1000	1195	-
DN150	-	-	-	-	-	-	-	1151	1570
DN200	-	-	-	-	-	-	-	-	1534
PN40									
DN10	335	347	-	-	-	-	-	-	-
DN15	341	353	510	-	-	-	-	-	-
DN25	-	-	514	600	-	-	-	-	-
DN40	-	-	-	610	709	-	-	-	-
DN50	-	-	-	-	715	895	-	-	-
DN80	-	-	-	-	-	915	986	-	-
DN100	-	-	-	-	-	-	1000	1205	-
DN150	-	-	-	-	-	-	-	1191	1580
DN200	-	-	-	-	-	-	-	-	1586
PN63									
DN50	-	-	-	-	743	923	-	-	-
DN80	-	-	-	-	-	943	1014	-	-
DN100	-	-	-	-	-	-	1026	1217	-
DN150	-	-	-	-	-	-	-	1231	1600

mm (±5)									
	S08	S10	S15	S25	S50	S80	S100	S150	S200
DN200	-	-	-	-	-	-	-	-	1630
PN100									
DN10	355	367	-	-	-	-	-	-	-
DN15	355	367	524	-	-	-	-	-	-
DN25	-	-	550	636	-	-	-	-	-
DN40	-	-	-	644	743	-	-	-	-
DN50	-	-	-	-	755	935	-	-	-
DN80	-	-	-	-	-	955	1026	-	-
DN100	-	-	-	-	-	-	1050	1221	-
DN150	-	-	-	-	-	-	-	1271	1640
DN200	-	-	-	-	-	-	-	-	1670
ASME 150									
½"	361	373	530	-	-	-	-	-	-
¾"	-	-	540	-	-	-	-	-	-
1"	-	-	546	632	-	-	-	-	-
1½"	-	-	-	644	743	-	-	-	-
2"	-	-	-	-	747	927	-	-	-
3"	-	-	-	-	-	939	1010	-	-
4"	-	-	-	-	-	-	1024	1195	-
6"	-	-	-	-	-	-	-	1219	1588
8"	-	-	-	-	-	-	-	-	1614
ASME 300									
½"	371	383	540	-	-	-	-	-	-
¾"	-	-	550	-	-	-	-	-	-
1"	-	-	558	644	-	-	-	-	-
1½"	-	-	-	658	757	-	-	-	-
2"	-	-	-	-	759	939	-	-	-
3"	-	-	-	-	-	959	1030	-	-
4"	-	-	-	-	-	-	1042	1213	-
6"	-	-	-	-	-	-	-	1239	1608
8"	-	-	-	-	-	-	-	-	1634
ASME 600									
½"	383	395	552	-	-	-	-	-	-
¾"	-	-	562	-	-	-	-	-	-
1"	-	-	572	658	-	-	-	-	-
1½"	-	-	-	674	773	-	-	-	-
2"	-	-	-	-	779	959	-	-	-
3"	-	-	-	-	-	979	1050	-	-

mm (± 5)									
	S08	S10	S15	S25	S50	S80	S100	S150	S200
4"	-	-	-	-	-	-	1088	1259	-
6"	-	-	-	-	-	-	-	1289	1658
8"	-	-	-	-	-	-	-	-	1690
JIS 10K									
50A	-	-	-	-	699	879	-	-	-
80A	-	-	-	-	-	889	960	-	-
100A	-	-	-	-	-	-	960	1195	-
150A	-	-	-	-	-	-	-	1147	1570
200A	-	-	-	-	-	-	-	-	1526
JIS 20K									
10A	331	343	-	-	-	-	-	-	-
15A	333	345	502	-	-	-	-	-	-
25A	-	-	510	596	-	-	-	-	-
40A	-	-	-	602	701	-	-	-	-
50A	-	-	-	-	703	883	-	-	-
80A	-	-	-	-	-	901	972	-	-
100A	-	-	-	-	-	-	986	1205	-
150A	-	-	-	-	-	-	-	1187	1580
200A	-	-	-	-	-	-	-	-	1564

inches (± 0.2)									
	S08	S10	S15	S25	S50	S80	S100	S150	S200
PN16									
DN80	-	-	-	-	-	-	38.2	-	-
DN100	-	-	-	-	-	-	39.4	47.0	-
DN150	-	-	-	-	-	-	-	45.3	61.8
DN200	-	-	-	-	-	-	-	-	60.4
PN40									
DN10	13.2	13.7	-	-	-	-	-	-	-
DN15	13.4	13.9	20.1	-	-	-	-	-	-
DN25	-	-	20.2	23.6	-	-	-	-	-
DN40	-	-	-	24.0	27.9	-	-	-	-
DN50	-	-	-	-	28.1	35.2	-	-	-
DN80	-	-	-	-	-	36.0	38.8	-	-
DN100	-	-	-	-	-	-	39.4	47.4	-
DN150	-	-	-	-	-	-	-	46.9	62.2
DN200	-	-	-	-	-	-	-	-	62.4

inches (± 0.2)									
	S08	S10	S15	S25	S50	S80	S100	S150	S200
PN63									
DN50	-	-	-	-	29.3	36.3	-	-	-
DN80	-	-	-	-	-	37.1	39.9	-	-
DN100	-	-	-	-	-	-	40.4	47.9	-
DN150	-	-	-	-	-	-	-	48.5	63.0
DN200	-	-	-	-	-	-	-	-	64.2
PN100									
DN10	14.0	14.4	-	-	-	-	-	-	-
DN15	14.0	14.4	20.6	-	-	-	-	-	-
DN25	-	-	21.7	25.0	-	-	-	-	-
DN40	-	-	-	25.4	29.3	-	-	-	-
DN50	-	-	-	-	29.7	36.8	-	-	-
DN80	-	-	-	-	-	37.6	40.4	-	-
DN100	-	-	-	-	-	-	41.3	48.1	-
DN150	-	-	-	-	-	-	-	50.0	64.6
DN200	-	-	-	-	-	-	-	-	65.7
ASME 150									
½"	14.2	14.7	20.9	-	-	-	-	-	-
¾"	-	-	21.3	-	-	-	-	-	-
1"	-	-	21.5	24.9	-	-	-	-	-
1½"	-	-	-	25.4	29.3	-	-	-	-
2"	-	-	-	-	29.4	36.5	-	-	-
3"	-	-	-	-	-	37.0	39.8	-	-
4"	-	-	-	-	-	-	40.3	47.0	-
6"	-	-	-	-	-	-	-	48.0	62.5
8"	-	-	-	-	-	-	-	-	63.5
ASME 300									
½"	14.6	15.1	21.3	-	-	-	-	-	-
¾"	-	-	21.7	-	-	-	-	-	-
1"	-	-	22.0	25.4	-	-	-	-	-
1½"	-	-	-	25.9	29.8	-	-	-	-
2"	-	-	-	-	29.9	37.0	-	-	-
3"	-	-	-	-	-	37.8	40.6	-	-
4"	-	-	-	-	-	-	41.0	47.8	-
6"	-	-	-	-	-	-	-	48.8	62.5
8"	-	-	-	-	-	-	-	-	63.5
ASME 600									
½"	15.1	15.6	21.7	-	-	-	-	-	-

inches (±0.2)									
	S08	S10	S15	S25	S50	S80	S100	S150	S200
¾"	-	-	22.1	-	-	-	-	-	-
1"	-	-	22.5	25.9	-	-	-	-	-
1½"	-	-	-	26.5	30.4	-	-	-	-
2"	-	-	-	-	30.7	37.8	-	-	-
3"	-	-	-	-	-	38.5	41.3	-	-
4"	-	-	-	-	-	-	42.8	49.6	-
6"	-	-	-	-	-	-	-	50.7	65.3
8"	-	-	-	-	-	-	-	-	66.5
JIS 10K									
50A	-	-	-	-	27.5	34.6	-	-	-
80A	-	-	-	-	-	35.0	37.8	-	-
100A	-	-	-	-	-	-	37.8	47.0	-
150A	-	-	-	-	-	-	-	45.2	61.8
200A	-	-	-	-	-	-	-	-	60.1
JIS 20K									
10A	13.0	13.5	-	-	-	-	-	-	-
15A	13.1	13.6	19.8	-	-	-	-	-	-
25A	-	-	20.1	23.5	-	-	-	-	-
40A	-	-	-	23.7	27.6	-	-	-	-
50A	-	-	-	-	27.7	34.8	-	-	-
80A	-	-	-	-	-	35.5	38.3	-	-
100A	-	-	-	-	-	-	38.8	47.4	-
150A	-	-	-	-	-	-	-	46.7	62.2
200A	-	-	-	-	-	-	-	-	61.6

Dimension B for meters with Hastelloy® and Stainless Steel (UNS S31803) measuring tubes

mm (±5)									
	H08	H10	H15	H25	H50	H80	D100	D150	D200
PN40									
DN15	329	354	-	-	-	-	-	-	-
DN25	-	-	511	-	-	-	-	-	-
DN40	-	-	-	601	-	-	-	-	-
DN50	-	-	-	-	714	-	-	-	-
DN80	-	-	-	-	-	914	-	-	-
PN63									
DN50	-	-	-	-	714	-	-	-	-
DN80	-	-	-	-	-	914	-	-	-

mm (±5)									
	H08	H10	H15	H25	H50	H80	D100	D150	D200
PN100									
DN15	329	354	-	-	-	-	-	-	-
DN25	-	-	511	-	-	-	-	-	-
DN40	-	-	-	601	-	-	-	-	-
DN50	-	-	-	-	714	-	-	-	-
DN80	-	-	-	-	-	914	-	-	-
PN160									
DN15	329	354	-	-	-	-	-	-	-
DN25	-	-	511	-	-	-	-	-	-
DN40	-	-	-	601	-	-	-	-	-
DN50	-	-	-	-	714	-	-	-	-
DN80	-	-	-	-	-	914	1042	-	-
DN100	-	-	-	-	-	-	1070	1241	-
DN150	-	-	-	-	-	-	-	1297	1666
DN200	-	-	-	-	-	-	-	-	1690
ASME 150									
½"	329	354	-	-	-	-	-	-	-
1"	-	-	511	-	-	-	-	-	-
1½"	-	-	-	601	-	-	-	-	-
2"	-	-	-	-	714	-	-	-	-
3"	-	-	-	-	-	914	-	-	-
ASME 300									
½"	329	354	-	-	-	-	-	-	-
1"	-	-	511	-	-	-	-	-	-
1½"	-	-	-	601	-	-	-	-	-
2"	-	-	-	-	714	-	-	-	-
3"	-	-	-	-	-	914	-	-	-
ASME 600									
½"	336	361	-	-	-	-	-	-	-
1"	-	-	518	-	-	-	-	-	-
1½"	-	-	-	608	-	-	-	-	-
2"	-	-	-	-	721	-	-	-	-
3"	-	-	-	-	-	921	-	-	-
ASME 900									
1½"	-	-	-	608	-	-	-	-	-
2"	-	-	-	-	721	-	-	-	-
3"	-	-	-	-	-	921	1088	-	-
4"	-	-	-	-	-	-	1112	1283	-

mm (± 5)									
	H08	H10	H15	H25	H50	H80	D100	D150	D200
6"	-	-	-	-	-	-	-	1335	1704
8"	-	-	-	-	-	-	-	-	1748
ASME 1500									
½"	336	361	-	-	-	-	-	-	-
1"	-	-	518	-	-	-	-	-	-
1½"	-	-	-	608	-	-	-	-	-
2"	-	-	-	-	721	-	-	-	-
3"	-	-	-	-	-	921	1118	-	-
4"	-	-	-	-	-	-	1132	1303	-
6"	-	-	-	-	-	-	-	1397	1766
8"	-	-	-	-	-	-	-	-	1850
JIS 10K									
50A	-	-	-	-	714	-	-	-	-
80A	-	-	-	-	-	914	-	-	-
JIS 20K									
15A	329	354	-	-	-	-	-	-	-
25A	-	-	511	-	-	-	-	-	-
40A	-	-	-	601	-	-	-	-	-
50A	-	-	-	-	714	-	-	-	-
80A	-	-	-	-	-	914	-	-	-

inches (± 0.2)									
	H08	H10	H15	H25	H50	H80	D100	D150	D200
PN40									
DN15	13.0	13.9	-	-	-	-	-	-	-
DN25	-	-	20.1	-	-	-	-	-	-
DN40	-	-	-	23.7	-	-	-	-	-
DN50	-	-	-	-	28.1	-	-	-	-
DN80	-	-	-	-	-	36.0	-	-	-
PN63									
DN50	-	-	-	-	28.1	-	-	-	-
DN80	-	-	-	-	-	36.0	-	-	-
PN100									
DN15	13.0	13.9	-	-	-	-	-	-	-
DN25	-	-	20.1	-	-	-	-	-	-
DN40	-	-	-	23.7	-	-	-	-	-
DN50	-	-	-	-	28.1	-	-	-	-

inches (± 0.2)									
	H08	H10	H15	H25	H50	H80	D100	D150	D200
DN80	-	-	-	-	-	36.0	-	-	-
PN160									
DN15	13.0	13.9	-	-	-	-	-	-	-
DN25	-	-	20.1	-	-	-	-	-	-
DN40	-	-	-	23.7	-	-	-	-	-
DN50	-	-	-	-	28.1	-	-	-	-
DN80	-	-	-	-	-	36.0	41.0	-	-
DN100	-	-	-	-	-	-	42.1	48.9	-
DN150	-	-	-	-	-	-	-	51.1	65.6
DN200	-	-	-	-	-	-	-	-	66.5
ASME 150									
1/2"	13.0	13.9	-	-	-	-	-	-	-
1"	-	-	20.1	-	-	-	-	-	-
1 1/2"	-	-	-	23.7	-	-	-	-	-
2"	-	-	-	-	28.1	-	-	-	-
3"	-	-	-	-	-	36.0	-	-	-
ASME 300									
1/2"	13.0	13.9	-	-	-	-	-	-	-
1"	-	-	20.1	-	-	-	-	-	-
1 1/2"	-	-	-	23.7	-	-	-	-	-
2"	-	-	-	-	28.1	-	-	-	-
3"	-	-	-	-	-	36.0	-	-	-
ASME 600									
1/2"	13.2	14.2	-	-	-	-	-	-	-
1"	-	-	20.1	-	-	-	-	-	-
1 1/2"	-	-	-	23.9	-	-	-	-	-
2"	-	-	-	-	28.4	-	-	-	-
3"	-	-	-	-	-	36.3	-	-	-
ASME 900									
1 1/2"	-	-	-	23.9	-	-	-	-	-
2"	-	-	-	-	28.4	-	-	-	-
3"	-	-	-	-	-	36.3	42.8	-	-
4"	-	-	-	-	-	-	43.8	50.5	-
6"	-	-	-	-	-	-	-	52.6	67.1
8"	-	-	-	-	-	-	-	-	68.8
ASME 1500									
1/2"	13.2	14.2	-	-	-	-	-	-	-
1"	-	-	20.4	-	-	-	-	-	-

inches (± 0.2)									
	H08	H10	H15	H25	H50	H80	D100	D150	D200
1½"	-	-	-	23.9	-	-	-	-	-
2"	-	-	-	-	28.4	-	-	-	-
3"	-	-	-	-	-	36.3	44.0	-	-
4"	-	-	-	-	-	-	44.6	51.3	-
6"	-	-	-	-	-	-	-	55.0	69.5
8"	-	-	-	-	-	-	-	-	72.8
JIS 10K									
50A	-	-	-	-	28.1	-	-	-	-
80A	-	-	-	-	-	36.0	-	-	-
JIS 20K									
15A	13.0	13.9	-	-	-	-	-	-	-
25A	-	-	20.1	-	-	-	-	-	-
40A	-	-	-	23.7	-	-	-	-	-
50A	-	-	-	-	28.1	-	-	-	-
80A	-	-	-	-	-	36.0	-	-	-

2.4.2 NAMUR dimensions

The following face to face dimensions comply with NAMUR NE132

mm (±3)						
	S15	S25	S50	S80	S100	S150
PN10						
DN250	-	-	-	-	-	-
PN16						
DN100	-	-	-	-	1000	-
DN150	-	-	-	-	-	1200 ①
DN200	-	-	-	-	-	-
PN40						
DN 15	510	-	-	-	-	-
DN 25	-	600	-	-	-	-
DN 50	-	-	715	-	-	-
DN 80	-	-	-	915	-	-
DN100					1000	-
DN150						1200 ①

① Available as special order

inches (±0.12)						
	S15	S25	S50	S80	S100	S150
PN10						
DN250	-	-	-	-	-	-
PN16						
DN100	-	-	-	-	39.4	-
DN150	-	-	-	-	-	47.2 ①
DN200	-	-	-	-	-	-
PN40						
DN 15	20.1	-	-	-	-	-
DN 25	-	23.6	-	-	-	-
DN 50	-	-	28.1	-	-	-
DN 80	-	-	-	36.0	-	-
DN100					39.4	-
DN150						47.2 ①

① Available as special order

2.4.3 Hygienic versions

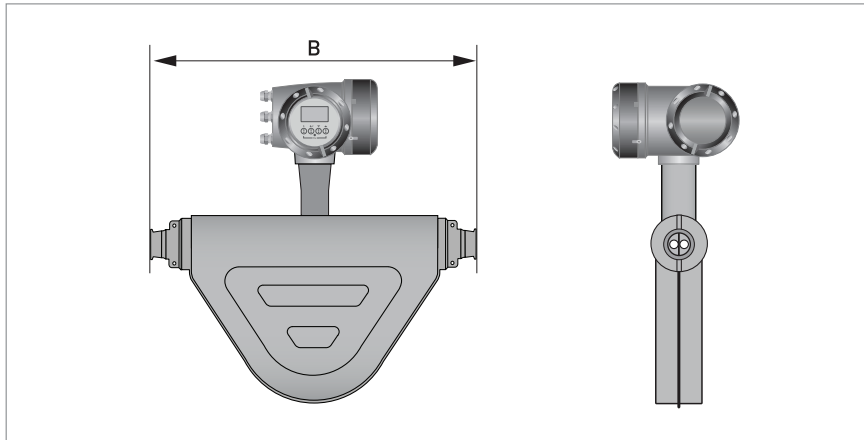

Dimension B for meters with Stainless Steel measuring tubes

	mm (±5)						
	S08	S10	S15	S25	S50	S80	S100
Tri-clover							
½"	312	322	-	-	-	-	-
¾"	312	322	-	-	-	-	-
1"	-	-	499	-	-	-	-
1½"	-	-	-	603	-	-	-
2"	-	-	-	-	694	-	-
3"	-	-	-	-	-	866	-
4"	-	-	-	-	-	-	916
Tri-clamp DIN 32676							
DN15	305	315	-	-	-	-	-
DN25	-	-	479	-	-	-	-
DN40	-	-	-	584	-	-	-
DN50	-	-	-	-	680	-	-
DN80	-	-	-	-	-	870	-
DN100	-	-	-	-	-	-	929
Tri-clamp ISO 2852							
1"	-	-	485	-	-	-	-
1½"	-	-	-	571	-	-	-
2"	-	-	-	-	670	-	-
3"	-	-	-	-	-	851	-
4"	-	-	-	-	-	-	916

	mm (± 5)						
	S08	S10	S15	S25	S50	S80	S100
DIN 11864-2 Form A (female)							
DN15	352	362	-	-	-	-	-
DN25	-	-	519	-	-	-	-
DN40	-	-	-	631	-	-	-
DN50	-	-	-	-	727	-	-
DN80	-	-	-	-	-	930	-
DN100	-	-	-	-	-	-	989
Male thread DIN 11851							
DN15	311	321	-	-	-	-	-
DN25	-	-	494	-	-	-	-
DN40	-	-	-	607	-	-	-
DN50	-	-	-	-	707	-	-
DN80	-	-	-	-	-	904	-
DN100	-	-	-	-	-	-	981
Male thread SMS							
1"	-	-	486	-	-	-	-
1½"	-	-	-	606	-	-	-
2"	-	-	-	-	697	-	-
3"	-	-	-	-	-	871	-
4"	-	-	-	-	-	-	929

	inches (± 0.2)						
	S08	S10	S15	S25	S50	S80	S100
Tri-clover							
½"	12.3	12.7	-	-	-	-	-
¾"	12.3	12.7	-	-	-	-	-
1"	-	-	19.6	-	-	-	-
1½"	-	-	-	23.7	-	-	-
2"	-	-	-	-	27.3	-	-
3"	-	-	-	-	-	34.1	-
4"	-	-	-	-	-	-	36.1
Tri-clamp DIN 32676							
DN15	12.0	12.4	-	-	-	-	-
DN25	-	-	18.9	-	-	-	-
DN40	-	-	-	23.0	-	-	-
DN50	-	-	-	-	26.8	-	-
DN80	-	-	-	-	-	34.3	-
DN100	-	-	-	-	-	-	36.6

	inches (±0.2)						
	S08	S10	S15	S25	S50	S80	S100
Tri-clamp ISO 2852							
1"	-	-	19.1	-	-	-	-
1½"	-	-	-	22.5	-	-	-
2"	-	-	-	-	26.4	-	-
3"	-	-	-	-	-	33.5	-
4"	-	-	-	-	-	-	36.1
DIN 11864-2 Form A (female)							
DN15	13.9	14.3	-	-	-	-	-
DN25	-	-	20.4	-	-	-	-
DN40	-	-	-	24.8	-	-	-
DN50	-	-	-	-	28.6	-	-
DN80	-	-	-	-	-	36.6	-
DN100	-	-	-	-	-	-	38.9
Male thread DIN 11851							
DN15	12.2	12.6	-	-	-	-	-
DN25	-	-	19.4	-	-	-	-
DN40	-	-	-	23.9	-	-	-
DN50	-	-	-	-	27.8	-	-
DN80	-	-	-	-	-	35.6	-
DN100	-	-	-	-	-	-	38.6
Male thread SMS							
1"	-	-	19.1	-	-	-	-
1½"	-	-	-	23.9	-	-	-
2"	-	-	-	-	27.4	-	-
3"	-	-	-	-	-	34.3	-
4"	-	-	-	-	-	-	36.6

2.4.4 Heating jacket version

Meter sizes 08...100

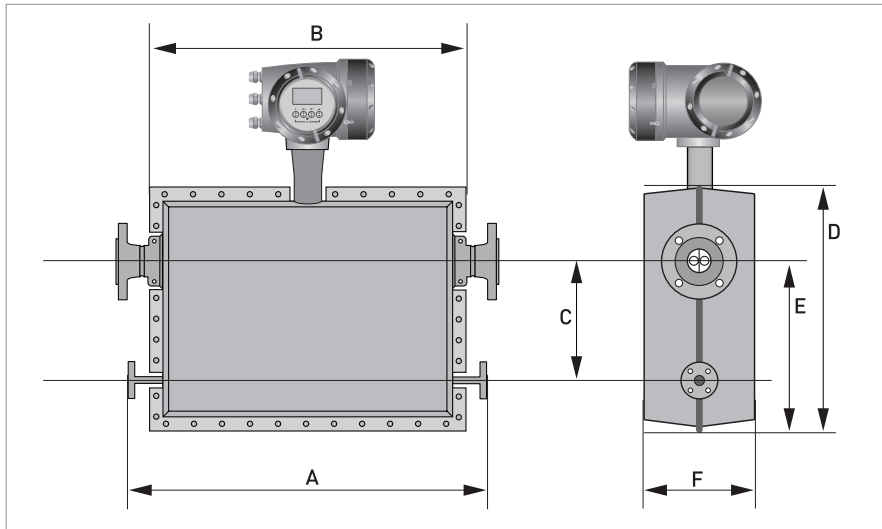

Meter sizes 150...200

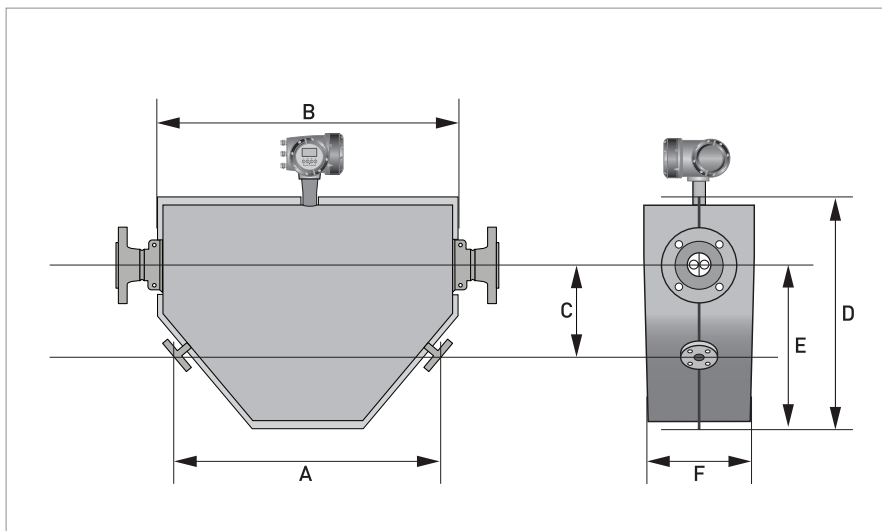

General dimensions

	mm								
	S08	S10	S15	S25	S50	S80	S100	S150	S200
Heating connection size: PN40 DN15 or ASME 150 ½"									
A ±5.0	435	550	660	685	860	925	847	1135	
B ±3.0	283	440	542	565	741	806	1036	1408	
C ±3.0	100	130	210	230	320	340	493	506	
D ±3.0	315	344	453	499	622	682	918	230	

	mm								
	S08	S10	S15	S25	S50	S80	S100	S150	S200
Heating connection size: PN40 DN15 or ASME 150 ½"									
E ±3.0	198	221	221	316	356	451	486	688	857
F ±3.0	232	226	226	254	266	322	372	414	500

	inches								
	S08	S10	S15	S25	S50	S80	S100	S150	S200
Heating connection size: PN40 DN15 or ASME 150 ½"									
A ±0.2	17.1	21.7	21.7	26.0	27.0	33.9	36.4	33.3	44.7
B ±0.12	11.1	17.3	17.3	21.3	22.2	29.2	31.7	40.8	55.4
C ±0.12	3.9	5.1	5.1	8.3	9.1	12.6	13.4	19.4	19.9
D ±0.12	12.4	13.5	13.5	17.8	19.6	24.5	26.9	36.1	9.1
E ±0.12	7.8	8.7	8.7	12.4	14.0	17.8	19.1	27.1	33.7
F ±0.12	9.1	8.9	8.9	10.0	10.5	12.7	14.6	16.3	19.7

2.4.5 Purge port option

If the meter has been ordered with purge ports, it will be supplied with two ports: one on the front and one on the rear.

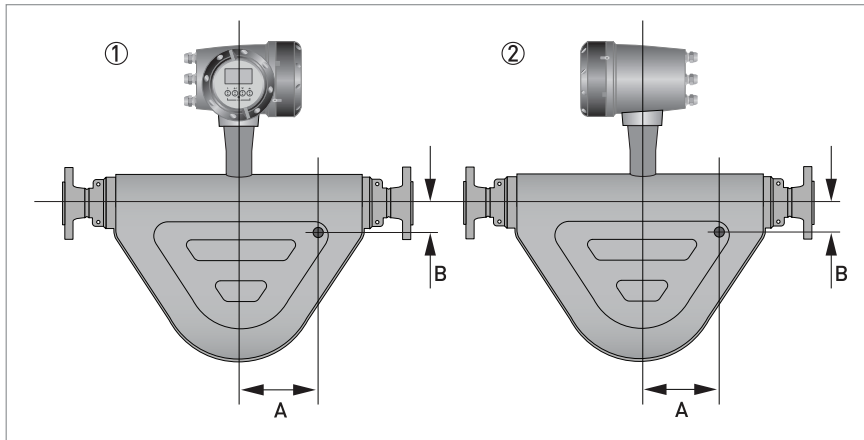

- ① Front view
- ② Rear view

Dimensions

	mm								
	S08	S10	S15	S25	S50	S80	S100	S150	S200
A	70		110	145	150	205	220	345	600
B	32		45	57	60	85		100	160

	inches								
	S08	S10	S15	S25	S50	S80	S100	S150	S200
A	2.8		4.3	5.7	5.9	8.1	8.7	13.6	23.6
B	1.3		1.8	2.2	2.4	3.3		3.9	6.3

2.4.6 Burst disc option

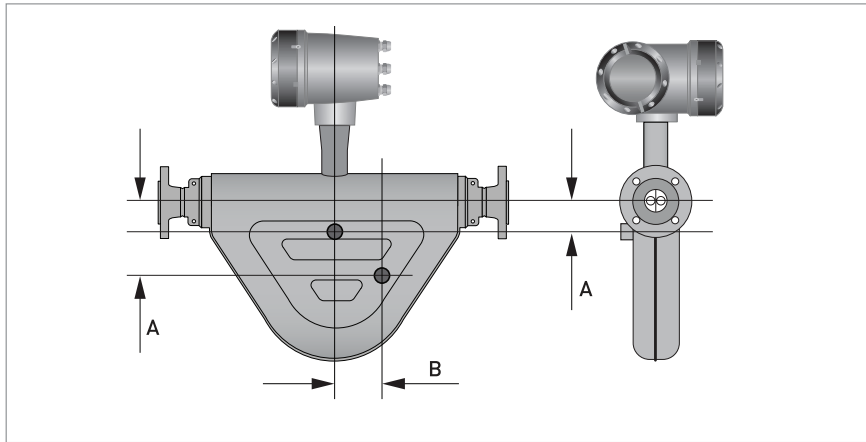

Dimensions

	mm								
	S08	S10	S15	S25	S50	S80	S100	S150	S200
A	76		92	135	57	74		175	195
B	38.5		62	0	0	0		0	0

	inches								
	S08	S10	S15	S25	S50	S80	S100	S150	S200
A	3.0		3.6	5.3	2.2	2.9		6.9	7.7
B	1.52		2.4	0	0	0		0	0

3.1 Intended use

This mass flowmeter is designed for the direct measurement of mass flow rate, product density and product temperature. Indirectly, it also enables the measurement of parameters like total mass, concentration of dissolved substances and the volume flow. For use in hazardous areas, special codes and regulations are also applicable and these are specified in separate documentation.

Responsibility for the use of the measuring devices with regard to suitability, intended use and corrosion resistance of the used materials against the measured fluid lies solely with the operator.

This device is a Group 1, Class A device as specified within CISPR11. It is intended for use in industrial environment. There may be potential difficulties in ensuring electromagnetic compatibility in other environments, due to conducted as well as radiated disturbances.

The manufacturer is not liable for any damage resulting from improper use or use for other than the intended purpose.

3.2 Mounting restrictions

3.2.1 General installation principles

There are no special installation requirements but you should note the following points:

- Support the weight of the meter as close to the meter body as possible.
- Mount the meter in such a way to avoid the build up of gas or liquid in the measuring tube.
- Straight runs either side of the meter are not required.
- The use of reducers and other fittings at flanges, including flexible hoses, is allowed but you should take care to avoid cavitation.
- Avoid extreme pipe size reductions.
- Meters are not affected by crosstalk and can be mounted in series or in parallel.
- Avoid mounting the meter at the highest point in the pipeline where air / gas can collect.

Mounting positions

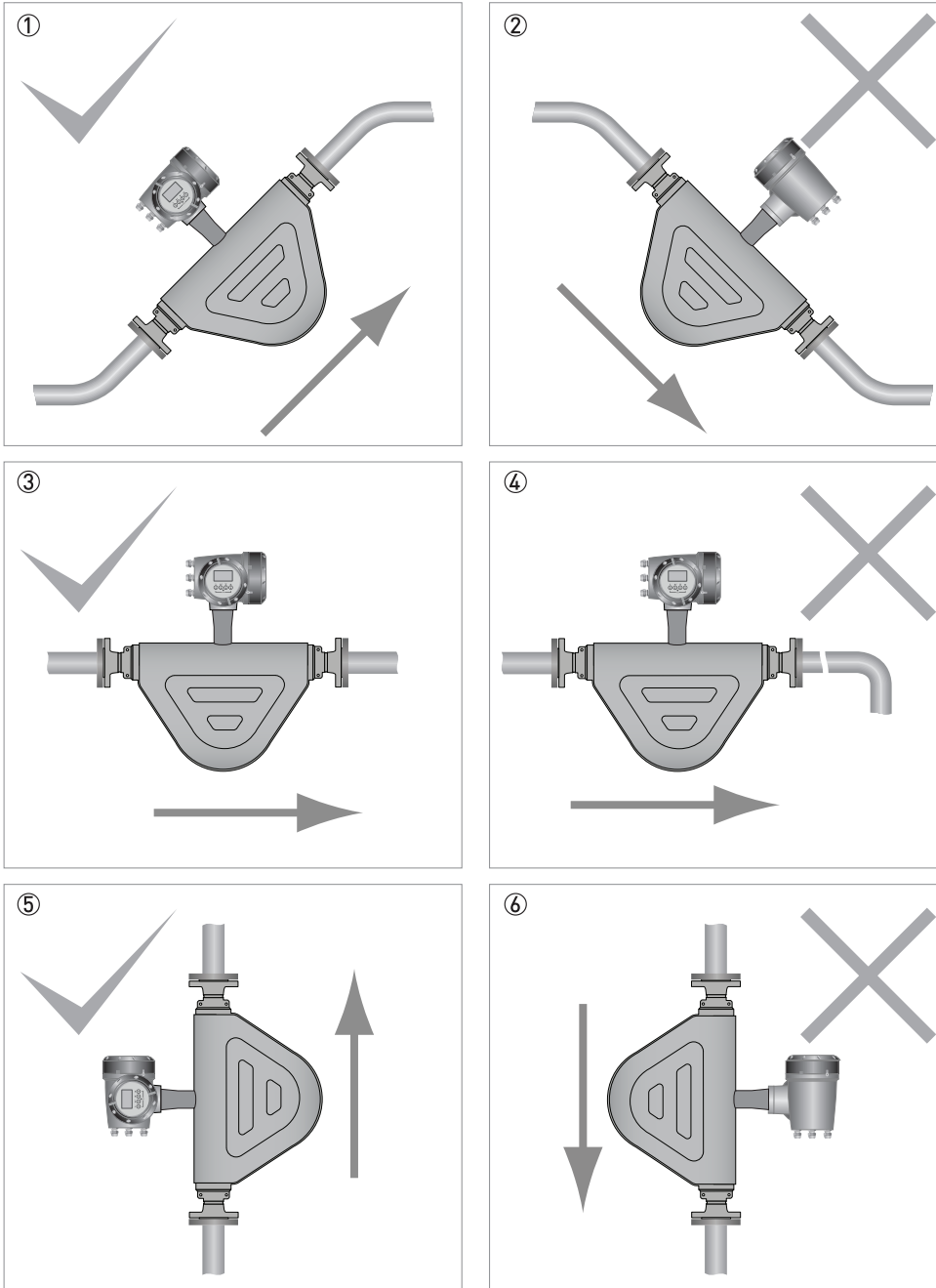

- ① The meter can be mounted at an angle but it is recommended that the flow is uphill.
- ② Avoid mounting the meter with the flow running downhill because it can cause siphoning. If the meter has to be mounted with the flow running downhill, install an orifice plate or control valve downstream of the meter to maintain backpressure.
- ③ Horizontal mounting with flow running left to right.
- ④ Avoid mounting meter with long vertical runs after the meter as it can cause cavitation. Where the installation includes a vertical run after the meter, install an orifice plate or control valve downstream to maintain backpressure.
- ⑤ The meter can be mounted vertically but it is recommended that the flow is uphill.
- ⑥ Avoid mounting the meter vertically with the flow running downhill. This can cause siphoning. If the meter has to be installed this way, install an orifice plate or control valve downstream to maintain backpressure.

Comprehensive installation guidance is provided in the Handbook

3.2.2 Maximum pipework forces (end loadings)

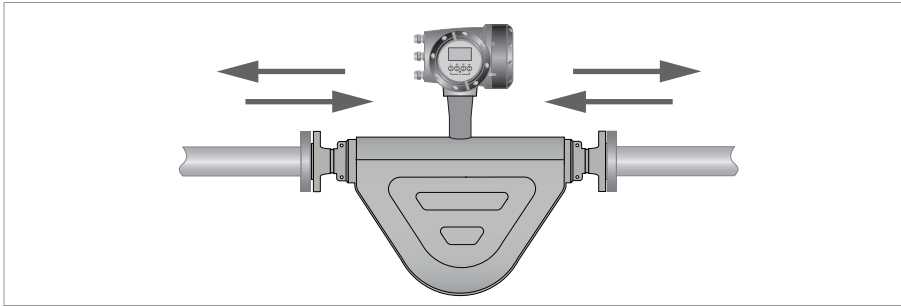

Mass flowmeters have a maximum level of force (negative or positive) that can be applied to the ends of the meter. Please refer to the Handbook for more information.

3.2.3 Sunshades

The meter **MUST** be protected from strong sunlight.

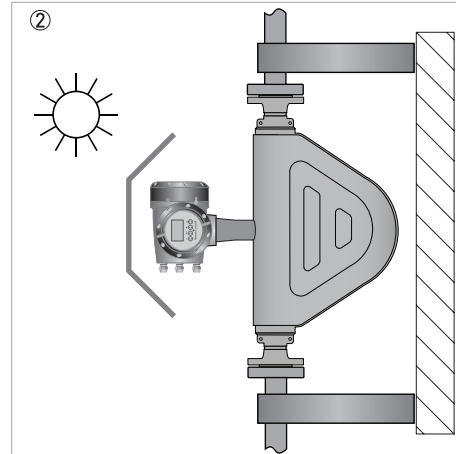
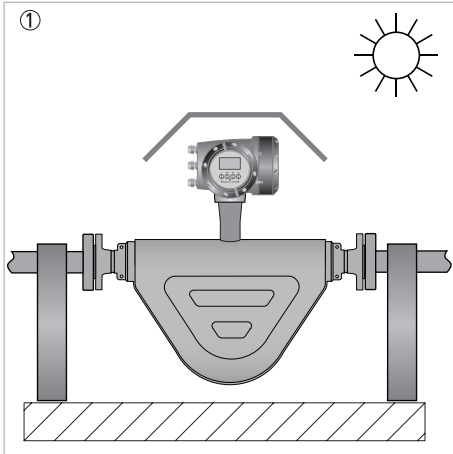

- ① Horizontal installation
- ② Vertical installation

Size	Code	Description
60Q...608	Tube material	
	S	Stainless Steel AISI 316 / 316L (1.4401 / 1.4404) dual certified
60Q...603	H	Hastelloy® C22
604...608	D	Stainless Steel UNS 31803 (1.4462)
All	Surface finish	
	0	Standard
60Q...604	2	Surface finish to Ra 0.8 µm
60Q	Flange connections	
	AA	DN10 PN40 to EN 1092-1
	AC	DN10 PN100 to EN 1092-1
	BA	DN15 PN40 to EN 1092-1
	BC	DN15 PN100 to EN 1092-1
	B4	DN15 PN160 to EN 1092-1
	KD	½" ASME 150 lb
	KE	½" ASME 300 lb
	KF	½" ASME 600 lb
	K1	½" ASME 900 lb
	K2	½" ASME 1500 lb
	TH	10A JIS 20K
	UH	15A JIS 20K
	Hygienic and aseptic connections	
BL	DN15 DIN 11864-2 Form A 'Nut' flange (female)	
BM	DN15 to DIN 11851 SC threaded ferrule (male)	
BN	DN15 Tri-clamp to DIN 32676	
KR	½" Tri-clamp (ASME BPE dimensions / Tri-clover)	
LR	¾" Tri-clamp (ASME BPE dimensions / Tri-clover)	
63E	Flange connections	
	AA	DN10 PN40 to EN 1092-1
	AC	DN10 PN100 to EN 1092-1
	BA	DN15 PN40 to EN 1092-1
	BC	DN15 PN100 to EN 1092-1
	B4	DN15 PN160 to EN 1092-1
	KD	½" ASME 150 lb
	KE	½" ASME 300 lb
	KF	½" ASME 600 lb
	K1	½" ASME 900 lb
	K2	½" ASME 1500 lb
	TH	10A JIS 20K
	UH	15A JIS 20K
	Hygienic and aseptic connections	
BL	DN15 DIN 11864-2 Form A 'Nut' flange (female)	
BM	DN15 to DIN 11851 SC threaded ferrule (male)	
BN	DN15 Tri-clamp to DIN 32676	
KR	½" Tri-clamp (ASME BPE dimensions / Tri-clover)	
LR	¾" Tri-clamp (ASME BPE dimensions / Tri-clover)	

Size	Code	Description	
60H	Flange connections		
	BA	DN15 PN40 to EN 1092-1	
	BC	DN15 PN100 to EN 1092-1	
	CA	DN25 PN40 to EN 1092-1	
	CC	DN25 PN100 to EN 1092-1	
	C4	DN25 PN160 to EN 1092-1	
	KD	½" ASME 150 lb	
	KE	½" ASME 300 lb	
	KF	½" ASME 600 lb	
	LD	¾" ASME 150 lb	
	LE	¾" ASME 300 lb	
	LF	¾" ASME 600 lb	
	MD	1" ASME 150 lb	
	ME	1" ASME 300 lb	
	MF	1" ASME 600 lb	
	M1	1" ASME 900 lb	
	M2	1" ASME 1500 lb	
	UH	15A JIS 20K	
	VH	25A JIS 20K	
60H	Hygienic and aseptic connections		
	CL	DN25 DIN 11864-2 Form A 'Nut' flange (female)	
	CM	DN25 to DIN 11851 SC threaded ferrule (male)	
	CN	DN25 Tri-clamp to DIN 32676	
	MR	1" Tri-clamp (ASME BPE dimensions / Tri-clover)	
	MT	1" Tri-clamp to ISO 2852	
	MV	25mm SMS (RD40 x 1/6 thread)	
601	Flange connections		
	CA	DN25 PN40 to EN 1092-1	
	CC	DN25 PN100 to EN 1092-1	
	DA	DN40 PN40 to EN 1092-1	
	DC	DN40 PN100 to EN 1092-1	
	D4	DN40 PN160 to EN 1092-1	
	MD	1" ASME150 lb	
	ME	1" ASME 300 lb	
	MF	1" ASME 600 lb	
	ND	1½" ASME 150 lb	
	NE	1½" ASME 300 lb	
	NF	1½" ASME 600 lb	
	N1	1½" ASME 900 lb	
	N2	1½" ASME 1500 lb	
	VH	25A JIS 20K	
	WH	40A JIS 20K	
	601	Hygienic and aseptic connections	
		DL	DN 40 DIN 11864-2 Form A 'Nut' flange (female)
		DM	DN 40 DIN 11851
DN		DN 40 Tri-clamp to DIN 32676	
NR		1½" Tri-clamp	
NT		1½" Tri-clamp to ISO 2852	
NV		1½" / 38mm SMS 1146 threaded ferrule (male)	

Size	Code	Description
602	Flange connections	
	DA	DN40 PN40 to EN 1092-1
	DC	DN40 PN100 to EN 1092-1
	EA	DN50 PN40 to EN 1092-1
	EB	DN50 PN63 to EN 1092-1
	EC	DN50 PN100 to EN 1092-1
	E4	DN50 PN160 to EN 1092-1
	ND	1½" ASME 150 lb
	NE	1½" ASME 300 lb
	NF	1½" ASME 600 lb
	PD	2" ASME 150 lb
	PE	2" ASME 300 lb
	PF	2" ASME 600 lb
	P1	2" ASME 900 lb
	P2	2" ASME 1500 lb
	WH	40A JIS 20K
	XG	50A JIS 10K
	XH	50A JIS 20K
	Hygienic and aseptic connections	
	EL	DN50 DIN 11864-2 Form A 'Nut' flange (female)
EM	DN50 DIN 11851 SC threaded sanitary connector	
EN	DN50 Tri-clamp to DIN 32676	
PR	2" Tri-clamp (ASME BPE dimensions/Tri-clover)	
PT	2" Tri-clamp to ISO 2852	
PV	51mm SMS (RD70 x 1/6 thread)	
603	Flange connections	
	EA	DN50 PN40 to EN 1092-1
	EB	DN50 PN63 to EN 1092-1
	EC	DN50 PN100 to EN 1092-1
	F7	DN80 PN16 to EN 1092-1
	FA	DN80 PN40 to EN 1092-1
	FB	DN80 PN63 to EN 1092-1
	FC	DN80 PN100 to EN 1092-1
	F4	DN80 PN160 to EN 1092-1
	PD	2" ASME 150 lb
	PE	2" ASME 300 lb
	PF	2" ASME 600 lb
	RD	3" ASME 150 lb
	RE	3" ASME 300 lb
	RF	3" ASME 600 lb
	R1	3" ASME 900 lb
	R2	3" ASME 1500 lb
	XG	50A JIS 10K
	XH	50A JIS 20K
	YG	80A JIS 10K
YH	80A JIS 20K	
Hygienic and aseptic connections		
FL	DN80 DIN 11864-2 Form A 'Nut' flange (female)	
FM	DN80 DIN 11851	
FN	DN80 Tri-clamp to DIN 32676	
RR	3" Tri-clover	
RT	3" Tri-clamp to ISO 2852	
RV	3" / 76mm SMS 1146 threaded ferrule (male)	

Size	Code	Description
604	Flange connections	
	F7	DN80 PN16 to EN 1092-1
	FA	DN80 PN40 to EN 1092-1
	FB	DN80 PN63 to EN 1092-1
	FC	DN80 PN100 to EN 1092-1
	F4	DN80 PN160 to EN 1092-1
	G7	DN100 PN16 to EN 1092-1
	GA	DN100 PN40 to EN 1092-1
	GB	DN100 PN63 to EN 1092-1
	GC	DN100 PN100 to EN 1092-1
	G4	DN100 PN160 to EN 1092-1
	RD	3" ASME 150 lb
	RE	3" ASME 300 lb
	RF	3" ASME 600 lb
	R1	3" ASME 900 lb
	R2	3" ASME 1500 lb
	SD	4" ASME 150 lb
	SE	4" ASME 300 lb
	SF	4" ASME 600 lb
	S1	4" ASME 900 lb
	S2	4" ASME 1500 lb
	YG	80A JIS 10K
	YH	80A JIS 20K
	ZG	100A JIS 10K
	ZH	100A JIS 20K
	Hygienic and aseptic connections	
	GL	DN100 DIN 11864-2 Form A 'Nut' flange (female)
GM	DN100 DIN 11851 SC threaded ferrule (male)	
GN	DN100 Tri-clamp to DIN 32676	
SR	4" Tri-clamp (ASME BPE dimensions / Tri-clover)	
ST	4" Tri-clamp to ISO 2852	
SV	101.6mm SMS (RD132 x 1/6 thread)	
606	Flange connections	
	G7	DN100 PN16 to EN 1092-1
	GA	DN100 PN40 to EN 1092-1
	GB	DN100 PN63 to EN 1092-1
	GC	DN100 PN100 to EN 1092-1
	G4	DN100 PN160 to EN 1092-1
	17	DN150 PN16 to EN 1092-1
	1A	DN150 PN40 to EN 1092-1
	1B	DN150 PN63 to EN 1092-1
	1C	DN150 PN100 to EN 1092-1
	14	DN150 PN160 to EN 1092-1
	SD	4" ASME 150 lb
	SE	4" ASME 300 lb
	SF	4" ASME 600 lb
	S1	4" ASME 900 lb
	S2	4" ASME 1500 lb
	4D	6" ASME 150 lb
	4E	6" ASME 300 lb
	4F	6" ASME 600 lb
	41	6" ASME 900 lb
42	6" ASME 1500 lb	

Size	Code	Description
608	Flange connections	
	17	DN150 PN16 to EN 1092-1
	1A	DN150 PN40 to EN 1092-1
	1B	DN150 PN63 to EN 1092-1
	1C	DN150 PN100 to EN 1092-1
	14	DN150 PN160 to EN 1092-1
	27	DN200 PN16, EN 1092-1
	2A	DN200 PN40 to EN 1092-1
	2B	DN200 PN63 to EN 1092-1
	2C	DN200 PN100 to EN 1092-1
	24	DN200 PN160 to EN 1092-1
	4D	6" ASME 150 lb
	4E	6" ASME 350 lb
	4F	6" ASME 600 lb
	41	6" ASME 900 lb
	42	6" ASME 1500 lb
	5D	8" ASME 150 lb
5E	8" ASME 300 lb	
5F	8" ASME 600 lb	
51	8" ASME 900 lb	
52	8" ASME 1500 lb	
All	Sealing face	
	0	Standard (type B1 for PN40 & B2 for PN63 and PN100 acc. EN 1092-1)
	C	EN 1092-1 type C with tongue
	D	EN 1092-1 type D with groove
	E	RTJ Acc ASME B16.5
	H	EN 1092-1 type F with recess
All	Design	
	0	Short stem (temperature range up to 150°C / 302°F)
	K	Extended stem (temperature range up to 230°C / 400°C / 446°F / 752°F)
All	Options	
	0	Without
	1	Insulation casing only (standard / high temperature)
	2	Insulation casing only (cryogenic / low temperature)
	3	Liquid/steam heating jacket DN15 PN40
	5	Liquid / steam heating jacket ½" ASME 150 lb
A	Purge fittings ½" NPT-F	
All	Hazardous areas approvals	
	0	Without
	1	ATEX Ex ia (T1-T6)
	7	NEPSI Ex ia
	A	cFMus GP (USA)
	B	cFMus OL (Canada)
	R	IEC Ex ia (T1-T6)
	T	cFMus (USA Standards)
U	cFMus (Canadian standards) / dual seal for liquids	
V	cFMus (Canadian standards) / dual seal for gases	
All	Hygienic / sanitary approvals / design approvals	
	0	Without
	M	NACE acc to MRO103 / ISO 17945
N	NACE acc to MRO175 / ISO 15156	
60Q...604	1	EHEDG
	2	3A

Size	Code	Description
All	Electronics configuration	
	0	Compact / integral mount
	1 2	Remote / field mount Aluminium junction box Remote / field mount SS junction box
All	Calibration	
	0	Standard 3 point mass flow calibration
	1	5 point calibration evenly spread across nominal flow rate
	2	5 point mass flow calibration bi-directional, plus ISO/IEC 17025 certificate
	3	3 point volume flow calibration
	4	5 point volume flow calibration
	5	5 point volume flow calibration bi-directional, plus ISO / IEC 17025 certificate
	A	0 plus custom density calibration with water at 3 temps and certificate
	B	1 plus custom density calibration with water at 3 temps and certificate
	D	1 plus ISO / IEC 17025 calibration certificate
	E	4 plus ISO / IEC 17025 calibration certificate
R	5 point mass flow 0.05% calibration, plus ISO/IEC 17025 certificate	
S	5 point mass flow 0.05% calibration with volume acc. ISO10790, plus ISO/IEC 17025 certificate	
606...608	G	10 point mass flow calibration, plus ISO/IEC 17025 certificate
	H	10 point volume flow calibration, plus ISO/IEC 17025 certificate
	K	10 point mass flow calibration bi-directional, plus ISO/IEC 17025 certificate
	L	10 point volume flow calibration bi-directional, plus ISO/IEC 17025 certificate
All	Process requirements	
	0	Standard
	1	Degreasing of wetted parts, plus certificate
	C	Cryogenic
	D	Cryogenic with degreasing (C+1)
T	High temperature [-50°C...400°C / -58°F...752°F]	
All	Extended options	
	0	Without, for liquids only
	1	Without, for gas applications < 10 bar
	U	MI 005 acc. MID 2014/32/EU for liquids other than water
	V	MI 002 acc. MID 2014/32/EU for fuel gases (including burst disc)
	4	Brasil INMETRO
	Z	acc. OIML R117-1 for liquids other than water
P	acc. OIML R137-1 for fuel gases, including burst disc	
G	Burst disc for gas applications	
60H...608	Y	USA NTEP
	F	Measurement Canada
All	Transmitter type	
	6 7	Compact Field mount
All	Functional safety	
	0	Without
	S	With SIL capability

ADDITIONAL PRODUCTS

These product lines offer a broad range of measurement and instrument products, including solutions for pressure, flow, analytical, temperature, positioning, controlling and recording.

For a list of these offerings, visit our website at:
www.se.com

Schneider Electric Systems USA, Inc. Global Customer Support
70 Mechanic Street Inside U.S.: 1-866-746-6477
Foxboro MA 02035-2037 Outside U.S.: 1-508-543-8750
United States of America <https://pasupport.schneider-electric.com>
<http://www.se.com>

Copyright 2021 Schneider Electric Systems USA, Inc.
All rights reserved.

The Schneider Electric brand and any trademarks of Schneider Electric SE or its subsidiaries are the property of Schneider Electric SE or its subsidiaries.
All other trademarks are the property of their respective owners.

